

11869A RF PLUG-IN ADAPTER

SERIAL NUMBERS

This manual applies directly to HP Model 11869A RF Plug-in Adapter having serial number prefix 2227A.

With changes described in Section VII, this manual also applies to instruments with serial number prefixes lower than 2227A.

For additional information about serial numbers, refer to INSTRUMENTS COVERED BY MANUAL in Section I.

© Copyright HEWLETT-PACKARD COMPANY 1983
1400 FOUNTAIN GROVE PARKWAY, SANTA ROSA, CA 95404 U.S.A.

MANUAL PART NO. 11869-90006
Microfiche Part No. 11869-90007

Printed: MARCH 1983



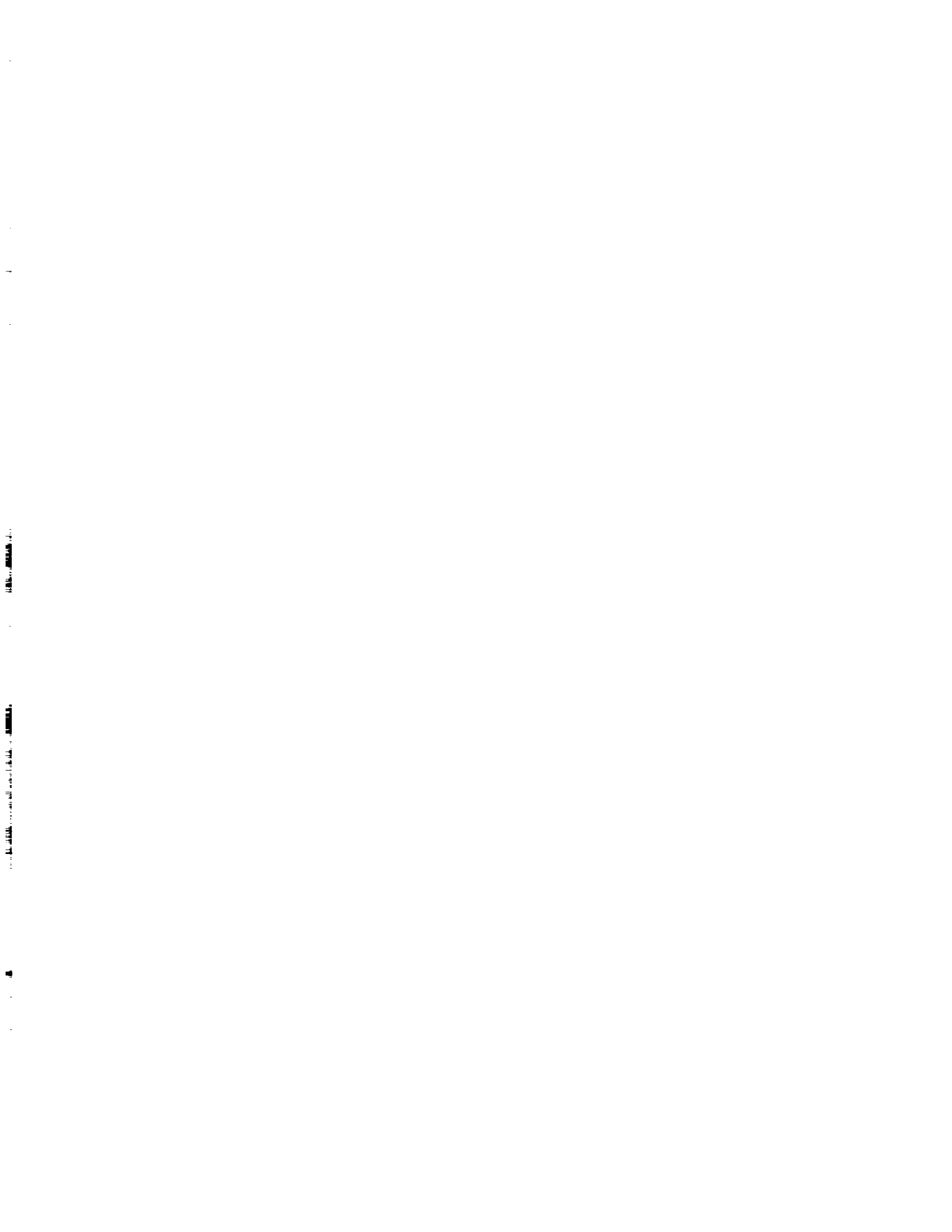

SAFETY CONSIDERATIONS

GENERAL

This product and related documentation must be reviewed for familiarization with safety markings and instructions before operation. This product has been designed and tested in accordance with international standards.

SAFETY SYMBOLS



Instruction manual symbol: the product will be marked with this symbol when it is necessary for the user to refer to the instruction manual (refer to Table of Contents).



Indicates hazardous voltages.



Indicates earth (ground) terminal.

WARNING

The **WARNING** sign denotes a hazard. It calls attention to a procedure, practice, or the like, which, if not correctly performed could result in personal injury. Do not proceed beyond a **WARNING** sign until the indicated conditions are fully understood and met.

CAUTION

The **CAUTION** sign denotes a hazard. It calls attention to an operating procedure, practice, or the like, which, if not correctly performed or adhered to, could result in damage to or destruction of part or all of the product. Do not proceed beyond a **CAUTION** sign until the indicated conditions are fully understood and met.

SERVICING

WARNING



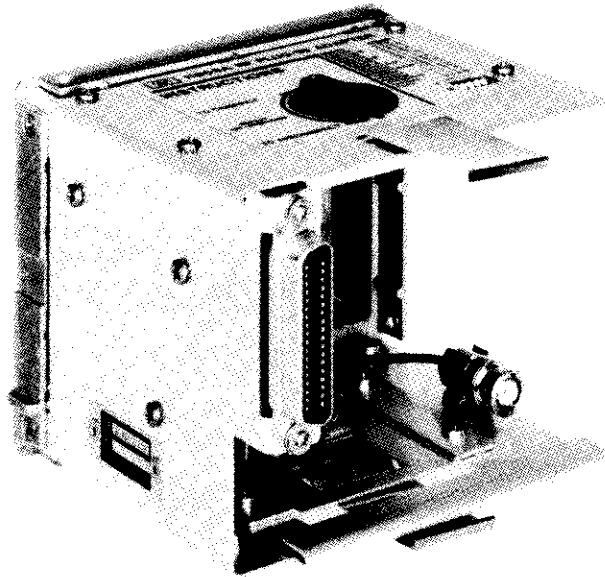

Any servicing, adjustment, maintenance, or repair of this product must be performed only by qualified personnel.

Adjustments described in this manual may be performed with power supplied to the product while protective covers are removed. Energy available at many points may, if contacted, result in personal injury.

11869A RF PLUG-IN ADAPTER



REAR PANEL CABLES

Blue - FREQ REF		(HP 11869-60012)
White - EXT ALC		(HP 11869-60015)
Grey - PULSE IN		(HP 11869-60014)
Violet - FM INPUT (Factory Installed)		(HP 11869-60013)

LATCH-HANDLE KIT
(HP 11869-60007)

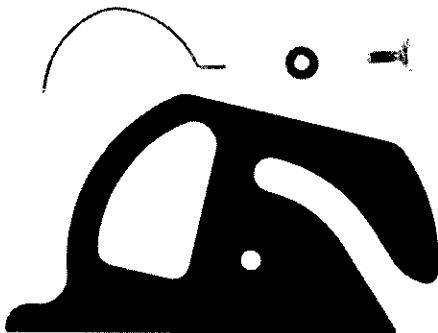

OPTION 006
AUX OUT CONNECTOR AND CABLE
(For instruments with rear panel AUX OUTPUT)

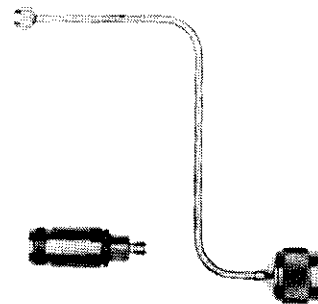

Figure 1-1. HP Model 11869A RF Plug-in Adapter and Accessories

SECTION I
GENERAL INFORMATION

1-1. INTRODUCTION

1-2. This Operating and Service Manual contains information required to install, operate, test, and service the Hewlett-Packard model 11869A RF Plug-In Adapter. Figure 1-1 shows the model 11869A and the latch handle and standard BNC Plug-In interconnect cables shipped with the instrument. Also shown in Figure 1-1 are the semi-rigid rear-panel AUX OUT cable and connector for the model 86290 Plug-Ins.

1-3. This Manual is divided into eight sections, which provide the following information:

- a. SECTION I, GENERAL INFORMATION, includes a brief description of the instrument, the operating characteristics, safety considerations, optional extras available, and a list of recommended test equipment.
- b. SECTION II, INSTALLATION, provides instructions for initial inspection, preparation for use, installation, storage, packaging, and shipment.
- c. SECTION III, OPERATION, presents information concerning the operating controls of the instrument.
- d. SECTION IV, PERFORMANCE TESTS, presents procedures to verify that the instrument is functioning correctly.
- e. SECTION V, ADJUSTMENTS. There are no electrical adjustments in the 11869A.
- f. SECTION VI, REPLACEABLE PARTS, provides information required to order all replaceable parts and assemblies.
- g. SECTION VII, MANUAL BACKDATING CHANGES, provides backdating information to make this Manual compatible with earlier shipment configurations.
- h. SECTION VIII, SERVICE, provides a key to component symbology, a table of mnemonics, an overall block diagram, circuit descriptions, schematic diagrams, component location diagrams, and troubleshooting information.

1-4. SPECIFICATIONS AND SUPPLEMENTAL CHARACTERISTICS

1-5. There are no specifications for the model 11869A Adapter. Table 1-1 lists supplemental characteristics, which are not specifications but typical characteristics included as information for the user.

1-6. SAFETY CONSIDERATIONS

1-7. General

1-8. The model 11869A is a Safety Class 1 instrument and has been manufactured and tested according to international safety standards.

1-9. Service

1-10. Although the instrument has been manufactured in accordance with international safety standards, this Manual contains information, cautions, and warnings which must be observed to ensure safe operation and to avoid damage to the instrument. Warnings and cautions appear where appropriate throughout the Manual. Service should be performed only by qualified personnel.

Table 1-1. Supplemental Characteristics of the HP 11869A (1 of 2)

11869A Adapter

The 11869A RF Plug-In Adapter provides the electrical and mechanical interface between the model 8350A Sweep Oscillator Mainframe and an 86200 series RF Plug-In. All of the 8350A's standard operating features including HP-IB remote programming are available. However, functions specific to the Plug-In (OUTPUT POWER LEVEL, RF ON/OFF, etc.) cannot be controlled or remotely programmed by the 8350A Mainframe.

Option 004 (Rear-Panel RF Output)

The 11869A Option 004 is designed for use with 86200 series Option 004 Plug-Ins (with rear-panel RF OUTPUT). The 11869A Option 004 is supplied with two pre-shaped semi-rigid coax cables with mating connectors to extend the RF OUT from the rear panel of the Plug-In to the rear panel of the 11869A Adapter, and with a Type-N(f) output connector. Two different RF OUT cables are supplied to match different Plug-In models (see Figure 1-3).

Option 006 (Rear-Panel AUX OUT Connector)

The 11869A Option 006 is designed for use with 86200 series Plug-Ins which have a rear-panel auxiliary output. The Option 006 is supplied with a pre-shaped semi-rigid cable to extend the AUX OUT from the rear panel of the Plug-In to the rear panel of the 11869A Adapter, and with a Type-N(f) output connector (see Figure 1-1). If the Plug-In is an Option 004 Plug-In (rear-panel RF output) which also has a rear-panel auxiliary output, the 11869A Adapter used is an Option 004 and Option 006.

Rear Panel Description

On the rear panel of the 11869A are five hole plugs that can be removed to allow connections to be made through the rear panel to the rear panel of the Plug-In. For user convenience the holes are labeled: AUX OUT, EXT ALC IN, RF OUT, PULSE IN, and FREQ REF.

Three short BNC interconnect cables are supplied to extend the Plug-In EXT ALC IN, PULSE IN, and FREQ REF to the rear panel of the 11869A Adapter for external access. A BNC-to-SMD cable is installed for connection of the 8350A FM INPUT signal through the Adapter to the rear panel of the Plug-In.

Table 1-1. Supplemental Characteristics of the HP 11869A (2 of 2)

Plug-In Compatibility with the 11869A/8350A

The 11869A Adapter attaches to the back of the 86200 series Plug-In and provides connections to the 8350A Mainframe. The Plug-In Identification Switch on the 11869A top panel is coded to interface the individual Plug-In with the 8350A. The Modulation Select Switch on the 11869A Connector Board selects the correct path for the squarewave modulation signal from the 8350A for use with each Plug-In.

The following Plug-Ins will operate in the 8350A Mainframe by using the 11869A Adapter.

MODEL	FREQUENCY RANGE
86220A	.01-1.3 GHz
86222A/B	.01-2.4 GHz
86230B	1.8-4.2 GHz
86235A	1.7-4.3 GHz
86240A/B	2-8.4 GHz
86240C	3.6-8.6 GHz
86241A	3.2-6.5 GHz
86242A/C/D	5.9-9.0 GHz
86245A	5.9-12.4 GHz
86250A/B/C/D	8.0-12.4 GHz
86260A	12.4-18 GHz
86290A	2-18 GHz
86290B/C	2-18.6 GHz
86290A/B Opt. HO8	2-22 GHz

Special Plug-Ins

For factory modified 86200 series Plug-Ins with non-standard frequency coverage a special PROM must be inserted in the 11869A Adapter. Consult your local HP Sales and Service Office for information about the PROM to be used in a specific Plug-In.

Plug-Ins Not Compatible with the 11869A Adapter

The 8621B RF Drawer and the 86300 series RF Modules are not compatible with the 11869A and will not operate in the 8350A Mainframe.

Furnished

Three BNC interconnect cables for extending the Plug-In rear panel inputs/outputs to the Adapter rear panel; a BNC to SMD cable (factory installed) for connecting the Plug-In FM INPUT from the Adapter/Mainframe; a latch handle with hardware for the Plug-In, to simplify installation in the 8350A Mainframe.

Weight: Net, 0.9 kg (2 lb). Shipping, 2.7 kg (6 lb).

1-11. INSTRUMENTS COVERED BY THE MANUAL

1-12. Attached to the side panel of the 11869A is a serial number plate similar to the one shown in Figure 1-2. The serial number is in two parts, a prefix and a suffix. The first four digits and the letter comprise the serial number prefix. The prefix is the same for all identical instruments; it is changed only when the instrument is modified. However, the numbers in the suffix are sequential, regardless of changes in the prefix. The suffix is different for each instrument. This Manual applies to instruments having the serial number prefix given under SERIAL NUMBERS on the title page.

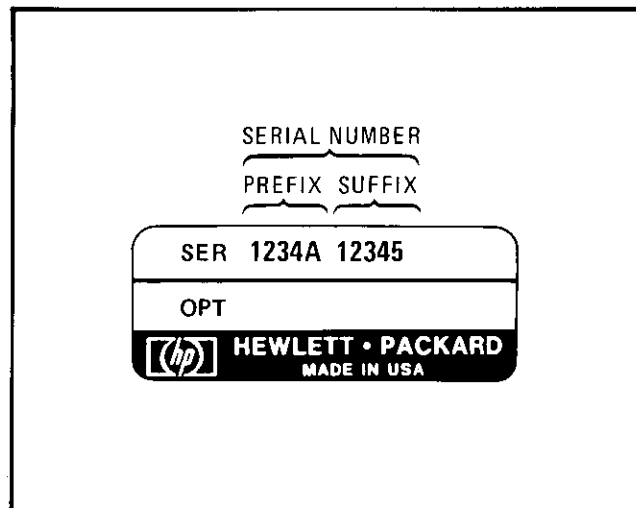

Figure 1-2. Typical Serial Number Plate

1-13. An instrument manufactured after the printing of this Manual might have a serial number prefix that is not given on the title page. This unlisted serial prefix indicates that the instrument is different from that described in the Manual. The Manual for this newer instrument will be accompanied by a yellow Manual Changes Supplement, which contains information explaining how to adapt the Manual for a newer instrument.

1-14. In addition to change information, the Supplement might contain information for correcting errors in the Manual. Such "errata" information applies to all serial numbers.

1-15. To keep this Manual as current and accurate as possible, Hewlett-Packard recommends that you periodically request the latest Manual Changes Supplement. The Supplement for this Manual is identified with the print date and part number of the Manual, both of which appear on the title page of the Manual. Complimentary copies of the Supplement are available from Hewlett-Packard. For information concerning a serial number prefix that is not given on the title page or in the Manual Changes Supplement, contact your nearest Hewlett-Packard Office.

1-16. DESCRIPTION

1-17. The HP model 11869A RF Plug-In Adapter provides a means for using the 86200 series RF Plug-Ins (designed for use in the 8620 Mainframe) in the 8350A Sweep Oscillator Mainframe. The 11869A Adapter locks on to an 86200 series RF Plug-In, then this assembly plugs into the Plug-In compartment of an 8350A Mainframe. The Adapter provides frequency range information to the Mainframe, as well as self-test circuits and various level shifting and interface functions.

1-18. OPTION 004 (REAR PANEL RF OUTPUT)

1-19. If the RF Plug-In is an Option 004 (rear-panel RF OUT), it is used with a model 11869A Option 004. The model 11869A Option 004 adds a semi-rigid cable kit to extend the RF output from the rear panel of the 86200 series RF Plug-In to the rear panel of the 11869A/8350A. Figure 1-3 shows the Option 004 rear-panel RF OUT cables and connectors.

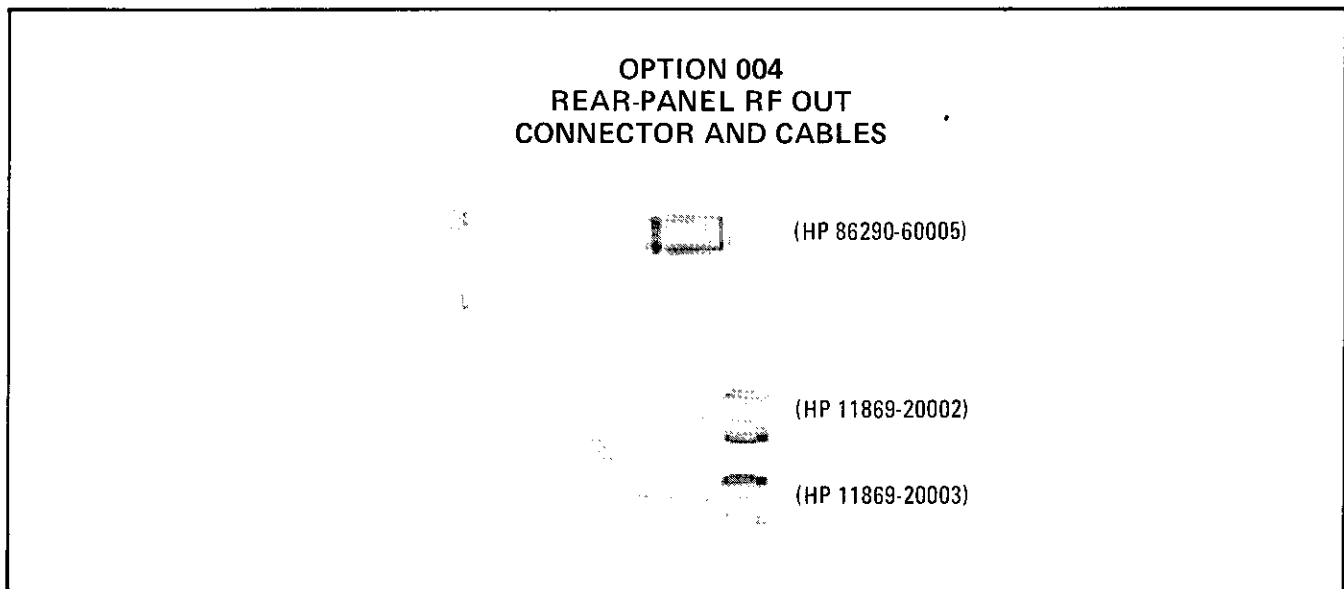

Figure 1-3. Option 004 Rear Panel RF Out Cables and Connectors

1-20. OPTION 006 (REAR PANEL AUX OUTPUT)

1-21. If the RF Plug-In has a rear-panel auxiliary output, it is used with a model 11869A Option 006. The Option 006 adds a semi-rigid cable kit to extend the auxiliary output from the rear panel of the Plug-In to the rear panel of the 11869A. The Option 006 cable and connector are shown in Figure 1-1. If the Plug-In is an Option 004 which also has a rear-panel auxiliary output, the 11869A Adapter used is an Option 004 and Option 006.

1-22. SPECIAL PROM MODULE

1-23. For RF Plug-Ins with non-standard frequency coverage (models not listed in Table 1-1), a special matching PROM module must be installed in the 11869A. Consult your HP Sales and Service Office for HP Part Numbers of PROMs for individual factory modified Special Plug-Ins.

1-24. LATCH HANDLE KIT

1-25. A kit containing a latch handle and mounting hardware for installing the 86200 series RF Plug-In in the 8350A Sweep Oscillator is supplied with the 11869A. Additional latch handle kits can be ordered using HP Part Number 11869-60007. The latch handle kit is shown in Figure 1-1.

1-26. OPTION 910, EXTRA MANUAL

1-27. The standard instrument is supplied with one Operating and Service Manual. Option 910 instruments are supplied with two Manuals.

1-28. RECOMMENDED TEST EQUIPMENT

1-29. Equipment required for testing the 11869A RF Plug-In Adapter is listed in Table 1-2. Other equipment may be substituted if it meets the critical specifications listed in the Table.

Table 1-2. Recommended Test Equipment

EQUIPMENT	CRITICAL SPECIFICATIONS	USE*
86200 series RF Plug-In	Any RF Plug-In listed in Table 1-1 will check the interface. However, the 86290A/B/C is recommended so that the band changing function may be checked.	P,T
8350A Sweep Oscillator	No substitute	P,T
1740A Oscilloscope	Dual channel, external sweep capability	P,T
8470B Crystal Detector	Frequency response 0.01 to 18 GHz	P,T
Adapter	Type N (m) to BNC (f)	P,T
Equipment for Residual FM Test	See Operating and Service Manual for RF Plug-In used.	P,T
*P=Performance Test T=Troubleshooting		

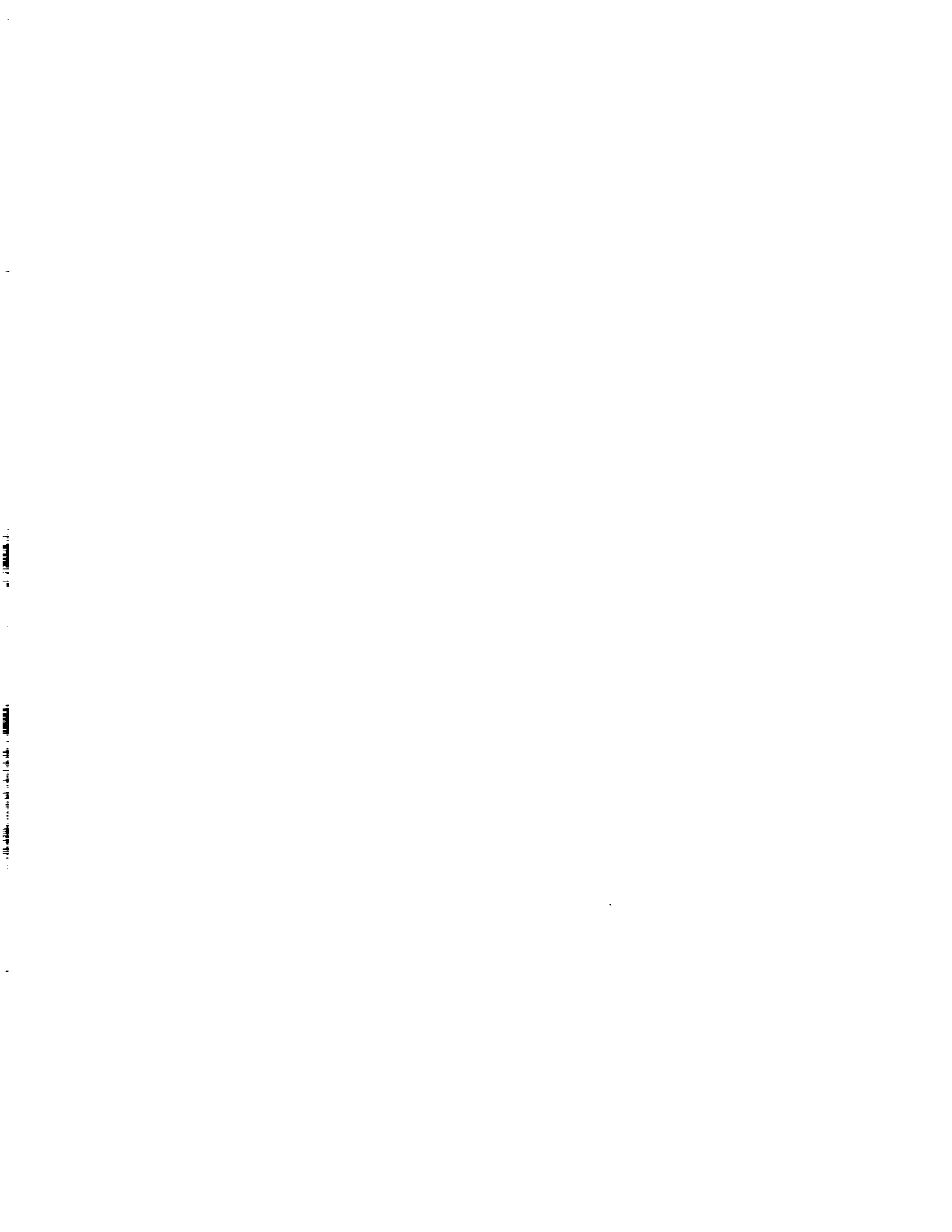

SECTION II

INSTALLATION

2-1. INTRODUCTION

2-2. This section provides installation instructions for the model 11869A RF Plug-In Adapter with an 86200 series RF Plug-In and a model 8350A Sweep Oscillator Mainframe. Also included are information concerning initial inspection and damage claims, preparation for use, operating environment, storage, packaging, and shipment.

2-3. INITIAL INSPECTION

2-4. Inspect the shipping container for damage. If the shipping container or cushioning material is damaged, it should be kept until the contents of the shipment have been checked for completeness and the instrument has been checked mechanically and electrically. The contents of the shipment should be as shown in Figure 1-1. Procedures for checking electrical performance are given in Section IV. If the contents are incomplete, if there is mechanical damage or defect, or if the instrument does not pass the electrical performance tests, notify the nearest Hewlett-Packard Office. If the shipping container is damaged, or the cushioning material shows signs of stress, notify the carrier as well as the Hewlett-Packard Office. Keep the shipping materials for the carrier's inspection. The Hewlett-Packard Office will arrange for repair or replacement without waiting for claim settlement.

2-5. PREPARATION FOR USE

2-6. Power Requirements

2-7. When the model 11869A RF Plug-In Adapter is properly installed, it obtains all power through the rear interface connectors from the HP model 8350A Sweep Oscillator Mainframe.

2-8. Interconnections

2-9. An 86200 series RF Plug-In is connected into the Plug-In Interface Connector of the model 11869A RF Plug-In Adapter and locked in place with the top and bottom clamps. This assembly (86200 series RF Plug-In and 11869A Plug-In Adapter) is then installed in the 8350A Sweep Oscillator Mainframe (see Figure 2-1). Proper connection is made when the two interface connectors on the rear panel of the Adapter mate with the Mainframe connectors. The three interface connectors and their input and output signals are shown in Figures 2-2, 2-3, and 2-4.

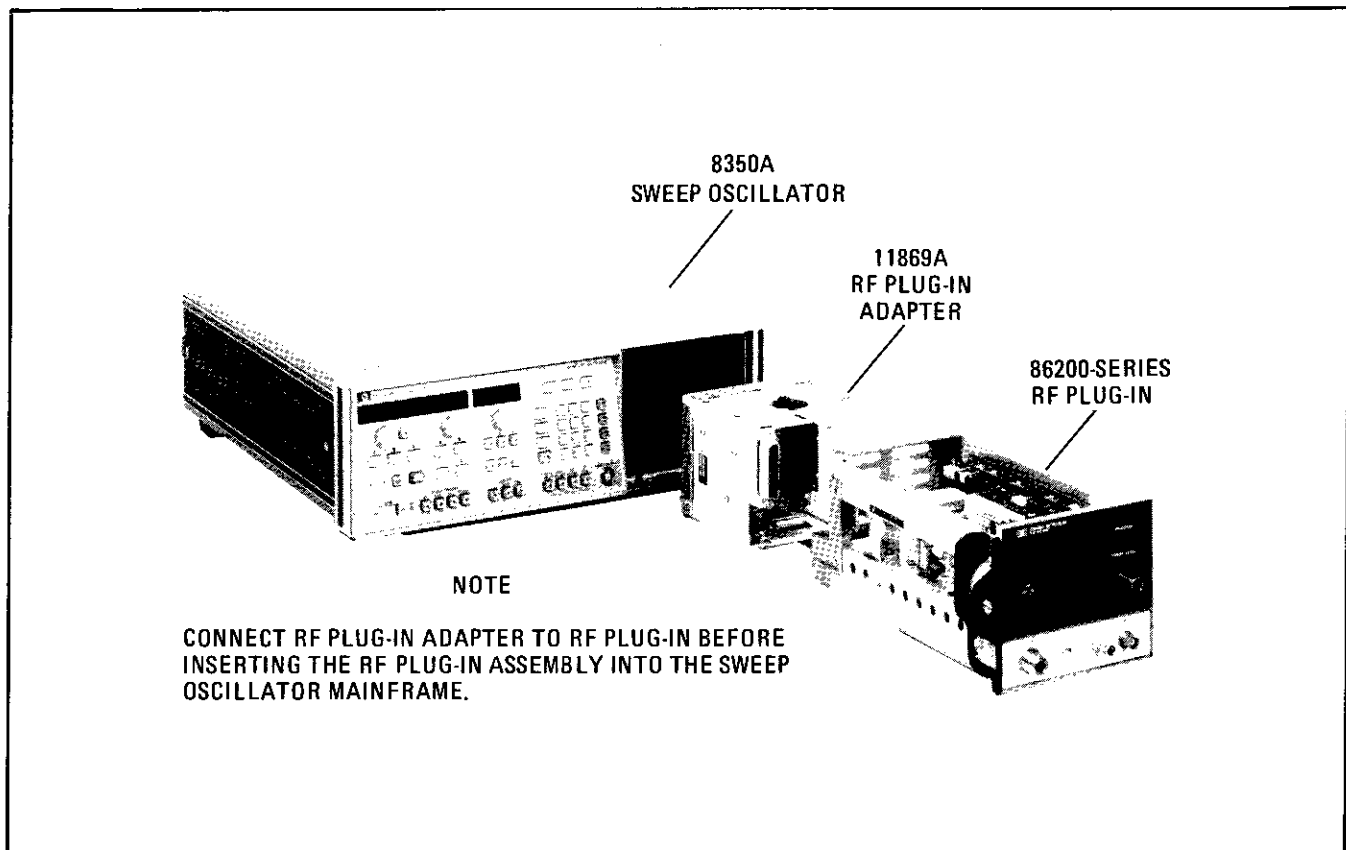

Figure 2-1. Mounting Plug-In into Mainframe

2-10. Operating Environment

2-11. Temperature. The instrument can be operated in temperatures from 0 degrees C to +55 degrees C.

2-12. Humidity. The instrument can be operated in environments with relative humidity up to 95%. However, the instrument should be protected from temperature extremes which might cause condensation within the instrument.

2-13. Altitude. The instrument can be operated at altitudes up to 4572 meters (15,000 feet).

2-14. INSTALLATION INSTRUCTIONS

2-15. Figure 2-5, Installation, gives instructions for connecting the 11869A Adapter to an 86200 series RF Plug-In and installing this assembly in an 8350A Sweep Oscillator Mainframe.

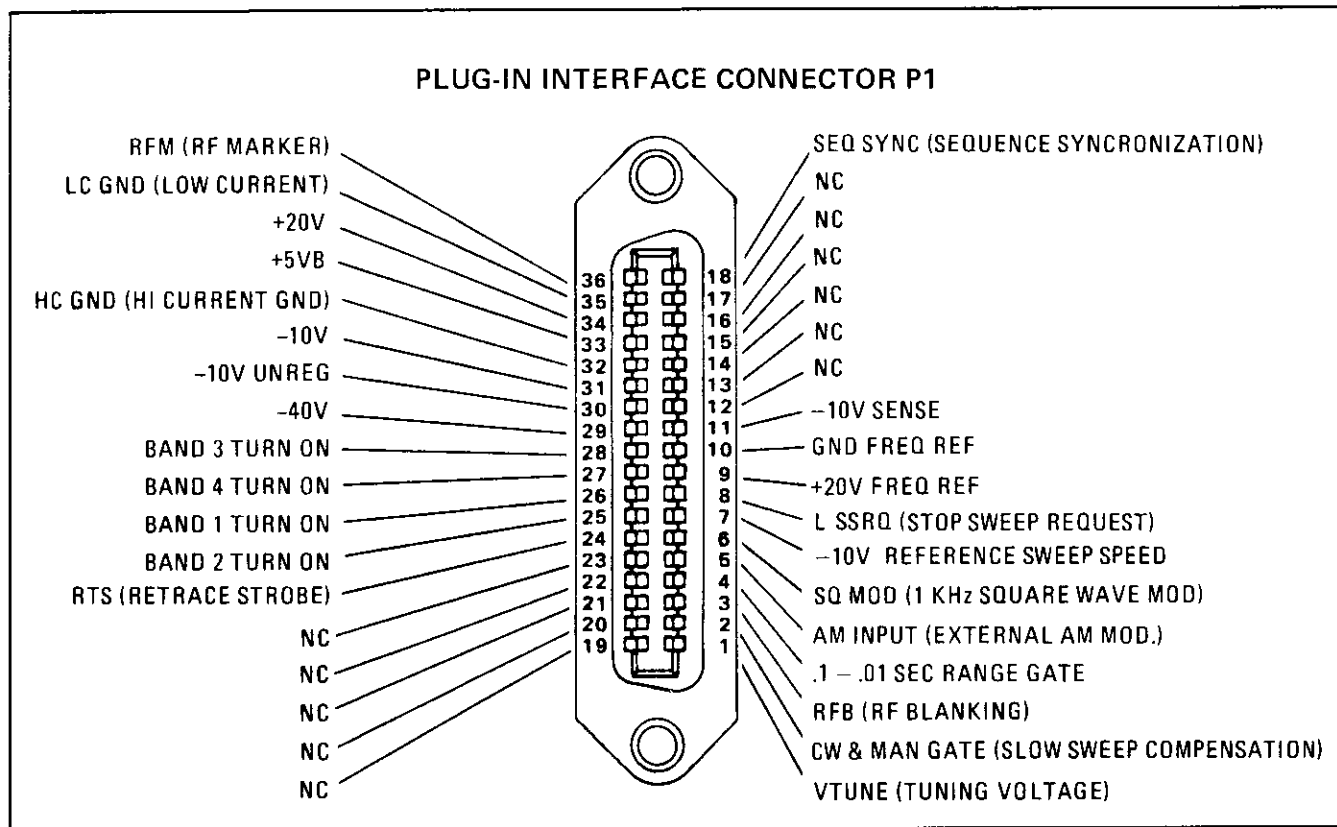

Figure 2-2. Plug-in Interface Signals on Connector P1

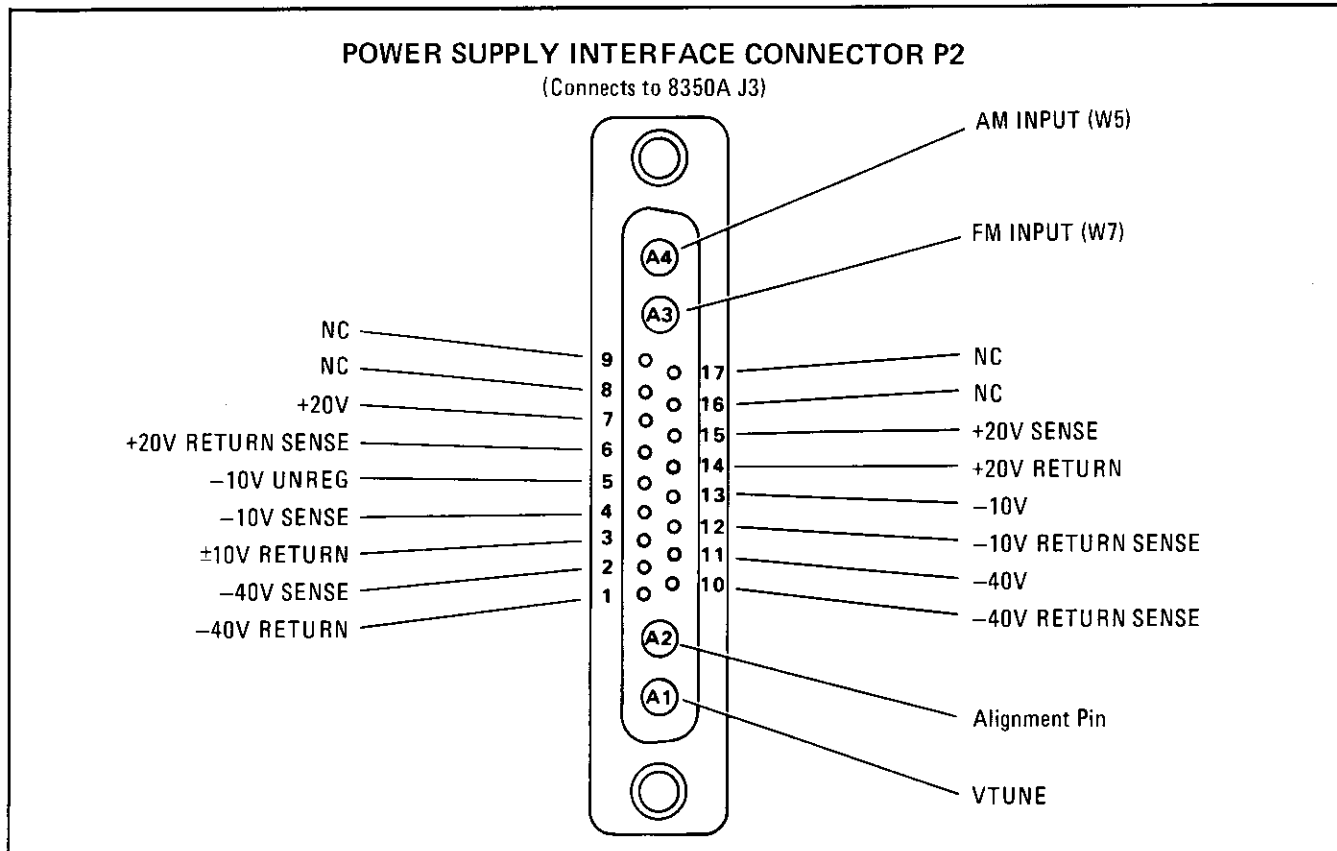

Figure 2-3. Power Supply Interface Signals on Connector P2

PLUG-IN INTERFACE CONNECTOR P3

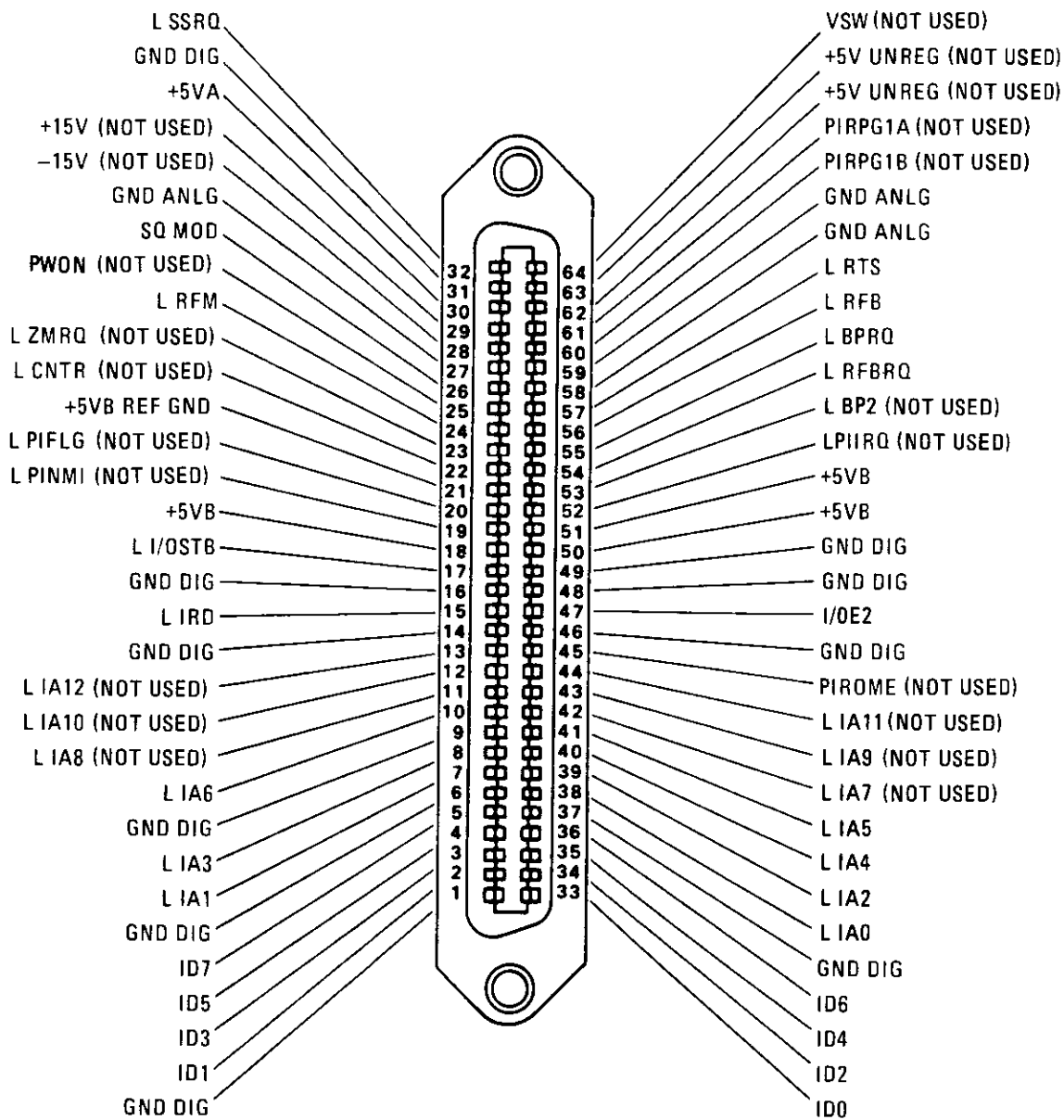

Figure 2-4. Mainframe Interface Signals on Connector P3

Figure 2-5. Installation (1 of 6)

1. Removing the Hole Plugs

Detach the rear panel of the 11869A Adapter by removing the four screws at the corners. To disengage the plugs from the connector holes, pry up the prongs with a soldering aid or other convenient tool. Push the plugs out of the holes and discard them. Replace the rear panel on the 11869A, making sure it is the right way up.

2. Installing the Special PROM ALU6

If the exact model number of the RF Plug-In is not listed on the 11869A above the Plug-In Identification Code Switch, it is a factory-modified Special Plug-In. The frequency range is non-standard, and a specially matched PROM must be installed in the 11869A Adapter to convey the correct frequency range information to the 8350A Mainframe. The special PROM can be ordered from the nearest Hewlett-Packard Sales and Service Office.

Insert the PROM into the socket ALXU6 provided on the Logic Board. See Figure 2-6 for the location of ALXU6.

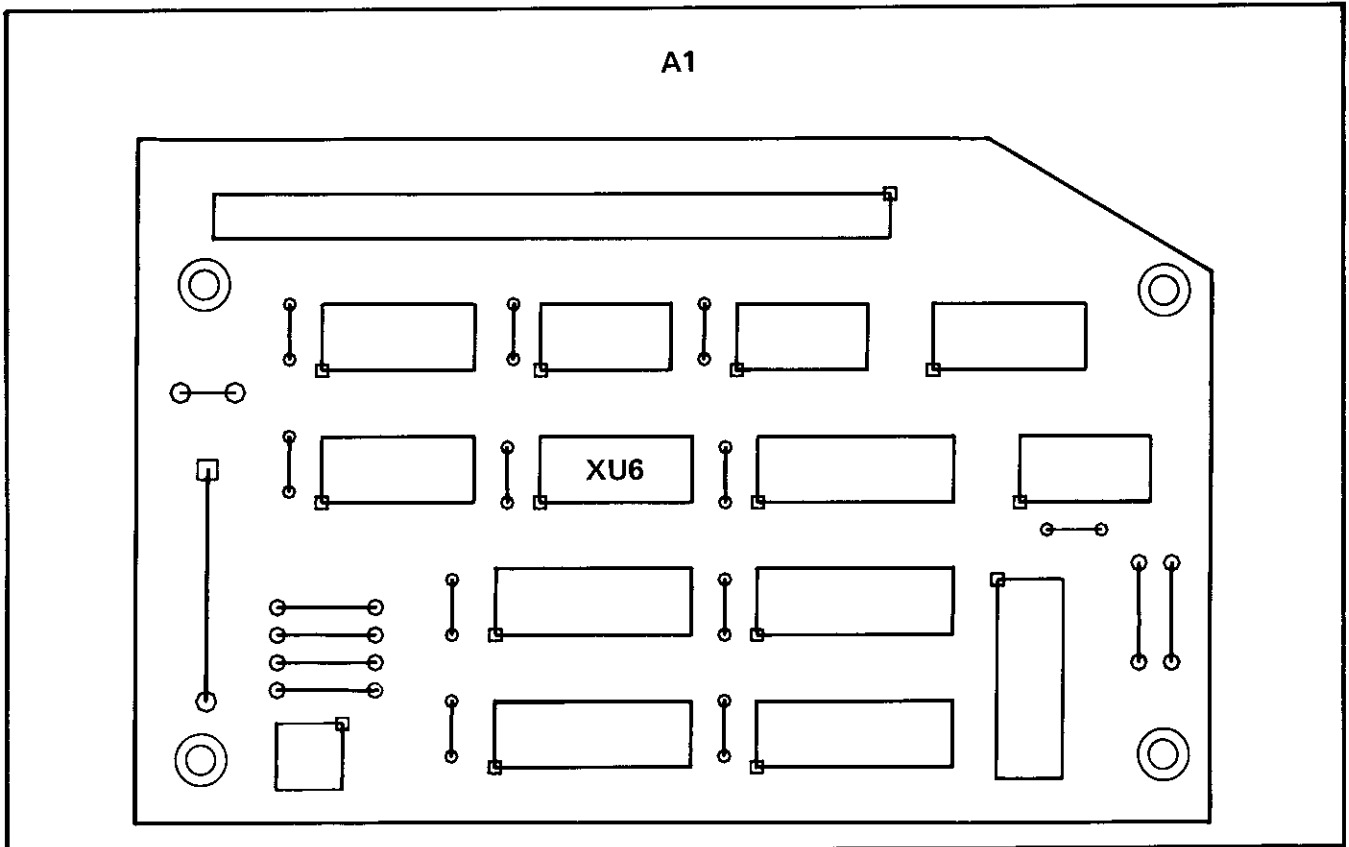

Figure 2-6. Location of Socket ALXU6 for Special PROM

Figure 2-5. Installation (2 of 6)

3. Setting the Modulation Select Switch

The Modulation Select Switch A2S1 selects the proper squarewave modulation input signal for each Plug-In model depending on its internal circuitry. Table 2-1 lists the settings of A2S1 for the individual Plug-In models.

Table 2-1. Modulation Select Switch Settings

Plug-In Model Number	A2S1 Position
*86220A	EXT
86222A/B	EXT
*86230B	EXT
86235A	EXT
86240A/B/C	EXT
*86241A	EXT
*86242A	EXT
86242C/D	INT
86245A	INT
*86250A/B	EXT
86250C/D	INT
*86260A/B/C	EXT
86290A/B/C	EXT
86290B HO8	EXT

NOTE

* Plug-Ins marked with an asterisk (*) are not compatible with 27.8 kHz internal squarewave modulation. For operation with the HP 8755 Frequency Response Test Set the front panel RF OUTPUT is modulated at 27.8 kHz with a model 11665B Modulator. The modulation drive signal for the 11665B is supplied by the 8755 MODULATOR DRIVE output. The 8350A squarewave modulation function is disabled by the front panel MOD key (light off). The externally modulated output cannot be HP-IB controlled.

Set the Modulation Select Switch to INT or EXT depending on the model number of the Plug-In. If the Plug-In is a factory-modified Special, select the switch setting for the corresponding Standard model of similar number.

Figure 2-5. Installation (3 of 6)

4. Adjusting the Clamp Position Plate

The clamp position plate on the bottom of the 11869A can be moved backward or forward to adjust the effective length of the clamp that attaches the Adapter to the Plug-In. Check the CLAMP ADJUST list beside the position plate for the correct placement of the position plate for the Plug-In to be installed. To move the clamp position plate, loosen the four retaining screws (Figure 2-7), slide the plate to the proper position, and re-tighten the retaining screws.

5. Extending the Clamps

Extend the clamps on the top and bottom of the 11869A by turning the clamp adjust knob according to the INSTRUCTIONS on the top panel. Turn the knob to the TO DISCONNECT position.

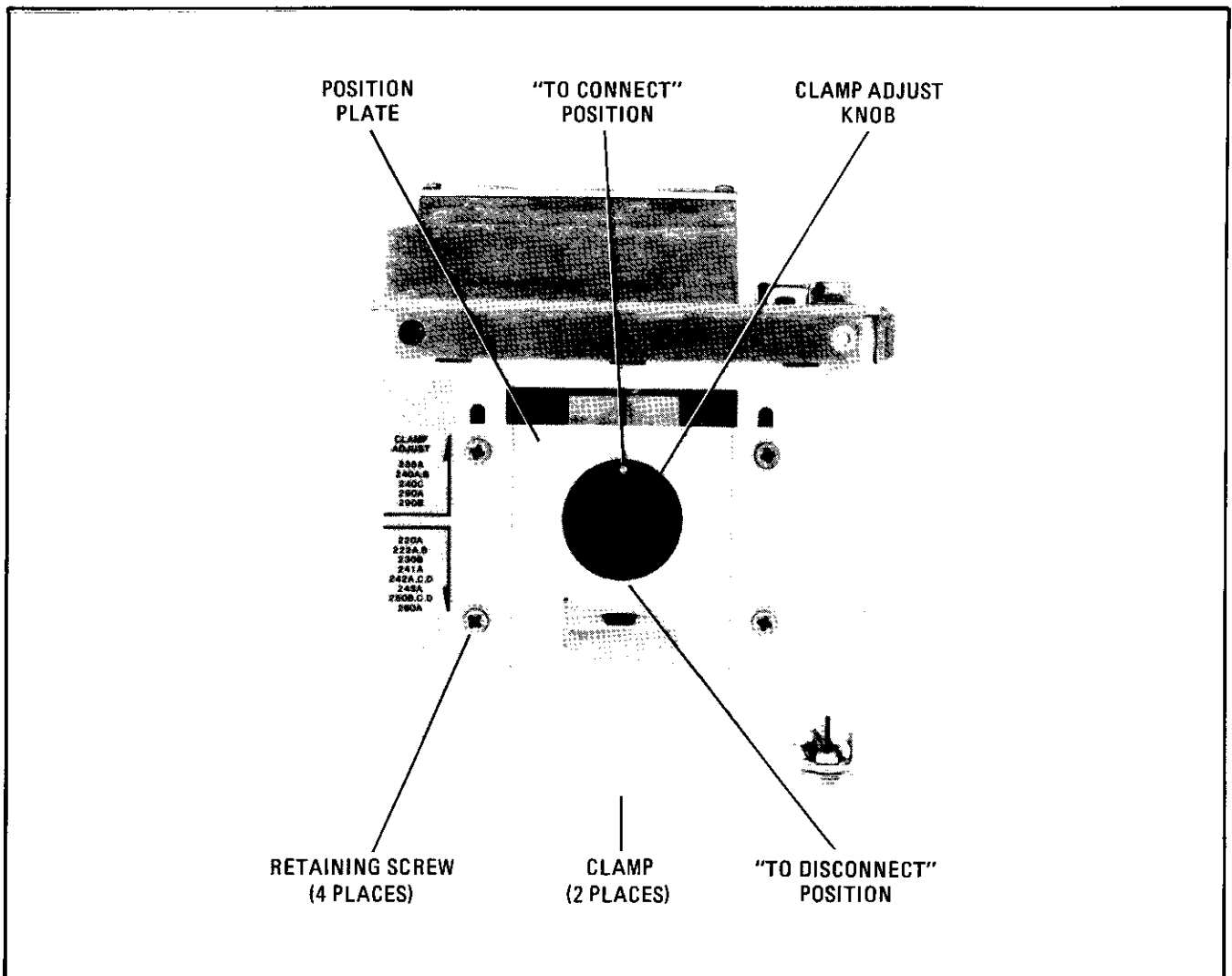

Figure 2-7. Clamp Position Plate

Figure 2-5. Installation (4 of 6)

6. Option 004: Connecting the RF OUT Cable

If the RF Plug-In is a model 86290A/B/C, clip off and discard the chain attached to the AUX OUT cover and the heat sink, to avoid possible short circuits on the Connector Board.

Select the correct semi-rigid Option 004 cable for the Plug-In used. Cable number 11869-20003 is used with the 86290A/B/C and cable number 11869-20002 is used with all others. Set the Plug-In right side up on a flat surface. Connect the Type-N(m) connector of the semi-rigid cable to the rear-panel RF OUT connector of the Plug-In. Keep the semi-rigid cable approximately parallel to the work surface and tighten the N-connector nut by hand.

The SMA end of the semi-rigid Option 004 cable is connected to the inside of the rear panel RF OUT connector on the 11869A Adapter at the same time as the Adapter is mated to the Plug-In. (See **Mating the Adapter to the Plug-In** below).

CAUTION

Do not over-tighten the SMA nut on the semi-rigid RF OUT cable. Excessive torque may cause internal damage to the cable connection. Tighten the nut snugly only.

After the Option 004 cable is connected to the 11869A Adapter and the Adapter is mated to the Plug-In, carefully tighten the SMA nut on the output end of the RF OUT cable, using a 5/16-inch wrench. Do not overtorque, as internal damage to the cable connection may result.

7. Option 006: Connecting the AUX OUT Cable

Remove the cover from the AUX OUT on the rear cover of the Plug-In, and clip off and discard the chain to avoid possible short circuits on the Connector Board.

To connect the AUX OUT cable, follow the instructions given above for the Option 004 rear-panel RF OUT cable, except connect the cable to the AUX OUT connector of the Plug-In and to the inside of the AUX OUT connector on the Adapter. If the Plug-In is an 86290A/B/C Option 004, connect both the RF OUT and the AUX OUT cables to the Plug-In before mating the 11869A Adapter to the Plug-In.

Figure 2-5. Installation (5 of 6)

8. Mating the Adapter to the Plug-In

CAUTION

Do not exert excessive turning pressure on the clamp adjust knob (Figure 2-7) or damage to the clamp mechanism may result.

Mate the Plug-In Interface Connector P1 of the 11869A Adapter with the corresponding connector on the RF Plug-In. Make sure that the top and bottom frames of the Adapter and the RF Plug-In are aligned. If an Option 004 rear-panel RF output cable or an Option 006 rear panel auxiliary output cable is being installed, connect the SMA end of the semi-rigid cable to the inside of the corresponding output connector on the rear panel of the 11869A Adapter. Rotate the black clamp adjust knobs on the top and bottom of the 11869A to the TO CONNECT position to retract the clamps and lock the two units together.

9. Connecting the BNC Cables

Three BNC interconnect cables are supplied in a separate package with the 11869A. The blue cable is the FREQ REF cable; the white cable is the EXT ALC IN cable; and the gray cable is the PULSE IN cable. Lock washers and hex nuts are supplied for all three cables, as well as two flat plastic insulators for the EXT ALC IN cable. The purple BNC to SMD cable for the FM Input is factory installed, with the BNC end held in a restraining clamp.

Push the female BNC connectors of the cables through the appropriate holes in the 11869A rear panel from the inside, and secure each with a lock washer and a hex nut on the outside. When installing the white EXT ALC IN cable, place plastic insulators on both sides of the hole. Tighten the hex nuts with a 9/16-inch wrench.

Connect the male BNC connectors of the cables to the corresponding female BNC connectors on the rear panel of the Plug-In. If the FM input is to be used, connect the purple cable to the FM connector of the Plug-In.

10. Setting the Plug-In Identification Switch

Locate the Plug-In Identification Switch A1S1 on the top panel of the 11869A Adapter. From the CODES list above the switch, select the code that corresponds with the Plug-In to be used, and set the four switch rockers to that code. If the exact model number of the RF Plug-In is not listed above switch A1S1, it is a factory modified Special Plug-In requiring the installation of a special matching PROM (see paragraph 2 above). If the Plug-In is a factory modified Special, encode switch A1S1 to 1111.

*Figure 2-5. Installation (6 of 6)***11. Installing the Latch Handle**

An improved latch handle for the RF Plug-In is supplied with the 11869A, together with a spring, washer, and flat screw for installation. The new latch is longer to conform with the shape of the 8350A, and when installed will protrude below the base of the Plug-In.

Remove the old latch handle from the left side of the Plug-In. Install the new latch in the same location, tensing the spring to fit behind the front panel of the Plug-In. Place the washer between the latch handle and the Plug-In, and tighten the screw to hold the latch handle in place.

12. Installing the Plug-In and Adapter in the Mainframe

Pull the latch handle on the left side of the Plug-In forward and upward. Install the Plug-In/Adapter assembly into the Plug-In compartment of the 8350A Mainframe. Push down on the latch to lock the Plug-In assembly into the 8350A. Interconnections between the Plug-In and the Mainframe are now complete.

2-16. STORAGE AND SHIPMENT**2-17. Environment**

2-18. The instrument can be stored or shipped in environments within the following limits:

Temperature	-40 degrees C to +75 degrees C
Humidity	Up to 95%
Altitude	Up to 7620 meters (25,000 feet)

The instrument should also be protected from temperature extremes which might cause condensation within the instrument.

2-19. Packaging

2-20. Original Packaging. Containers and materials identical to those used in factory packaging are available through Hewlett-Packard Offices. If the instrument is being returned to Hewlett-Packard for servicing, attach a tag indicating the type of service required, return address, model number, and full serial number. Also, mark the container FRAGILE to assure careful handling. In any correspondence, refer to the instrument by model number and full serial number.

2-21. Other packaging. The following general instructions should be used for repackaging with commercially available materials:

- a. Wrap instruments in heavy paper or plastic. (If shipping to a Hewlett-Packard Office or Service Center, attach a tag indicating the type of service required, return address, model number, and full serial number.)
- b. Use a strong shipping container. A double-wall carton made of 160-kilogram (approximately 350-pound) test material is adequate.
- c. Use enough shock-absorbing material (8- to 10-cm. layer) around all sides of the instrument to provide a firm cushion and to prevent movement inside the container.
- d. Seal the shipping container securely.
- e. Mark the shipping container FRAGILE to ensure careful handling.
- f. In any correspondence, refer to the instrument by model number and full serial number.

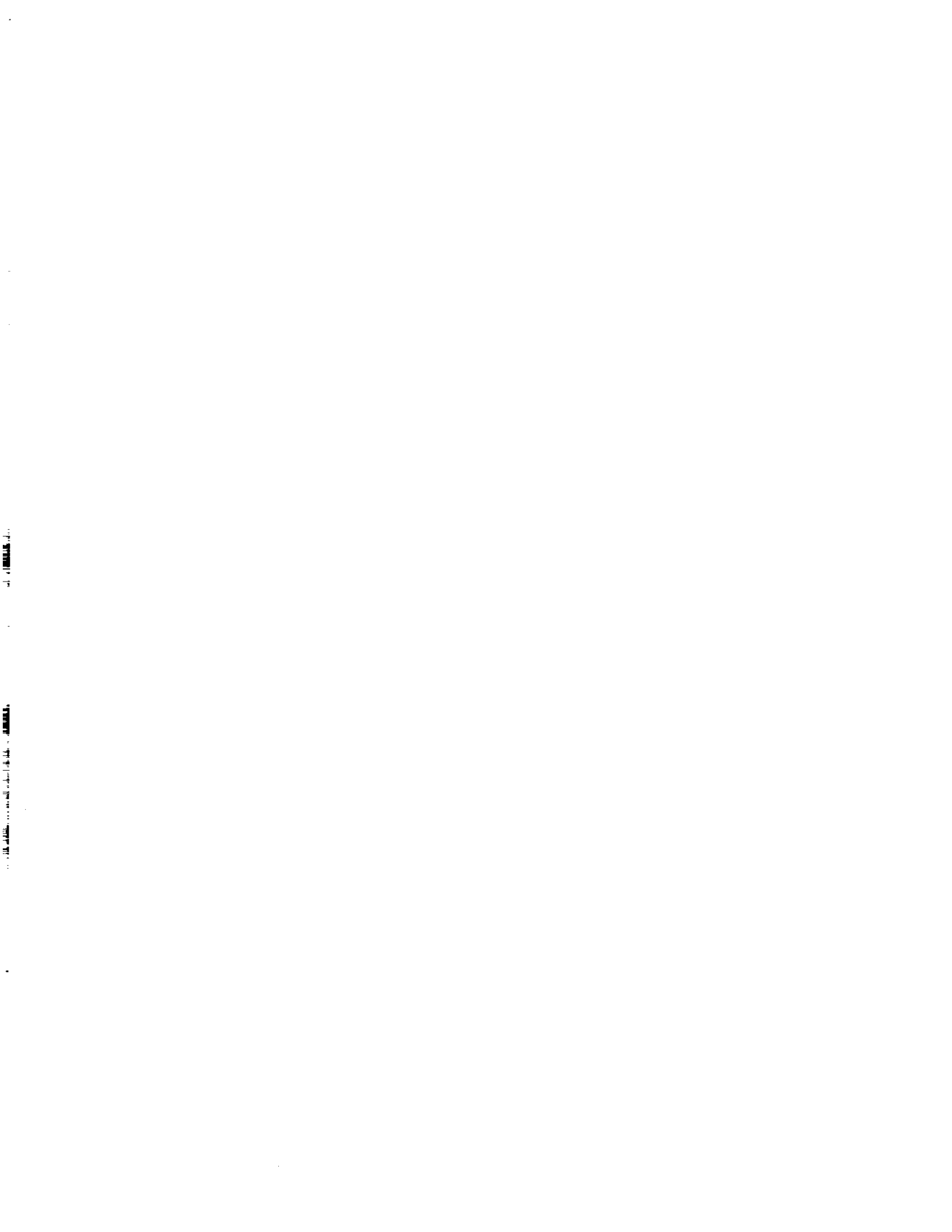

SECTION III**OPERATION****3-1. INTRODUCTION**

3-2. The HP 11869A RF Plug-In Adapter has only two operating controls. These are the Modulation Select Switch A2S1 on the Connector Board, and the Plug-In Identification Switch A1S1 located on the top panel. These switches are set prior to installation. The settings vary according to the individual Plug-In to be installed (see Section II of this Manual for instructions).

3-3. The Modulation Select Switch A2S1 selects the proper squarewave modulation input signal for the Plug-In. The Plug-In Identification Switch A1S1 (Figure 3-1) consists of four rockers which are encoded to identify the specific Plug-In mated to the 11869A Adapter. The setting of A1S1 is interrogated by the 8350A at Power On, at Instrument Preset (when the front panel INSTR PRESET button is pressed), or when an HP-IB 'IP' command is received. The switch information is decoded by the 8350A and translated to a START/STOP frequency range to match the Plug-In.

3-4. For additional operating instructions refer to the 8350A Operating and Service Manual.

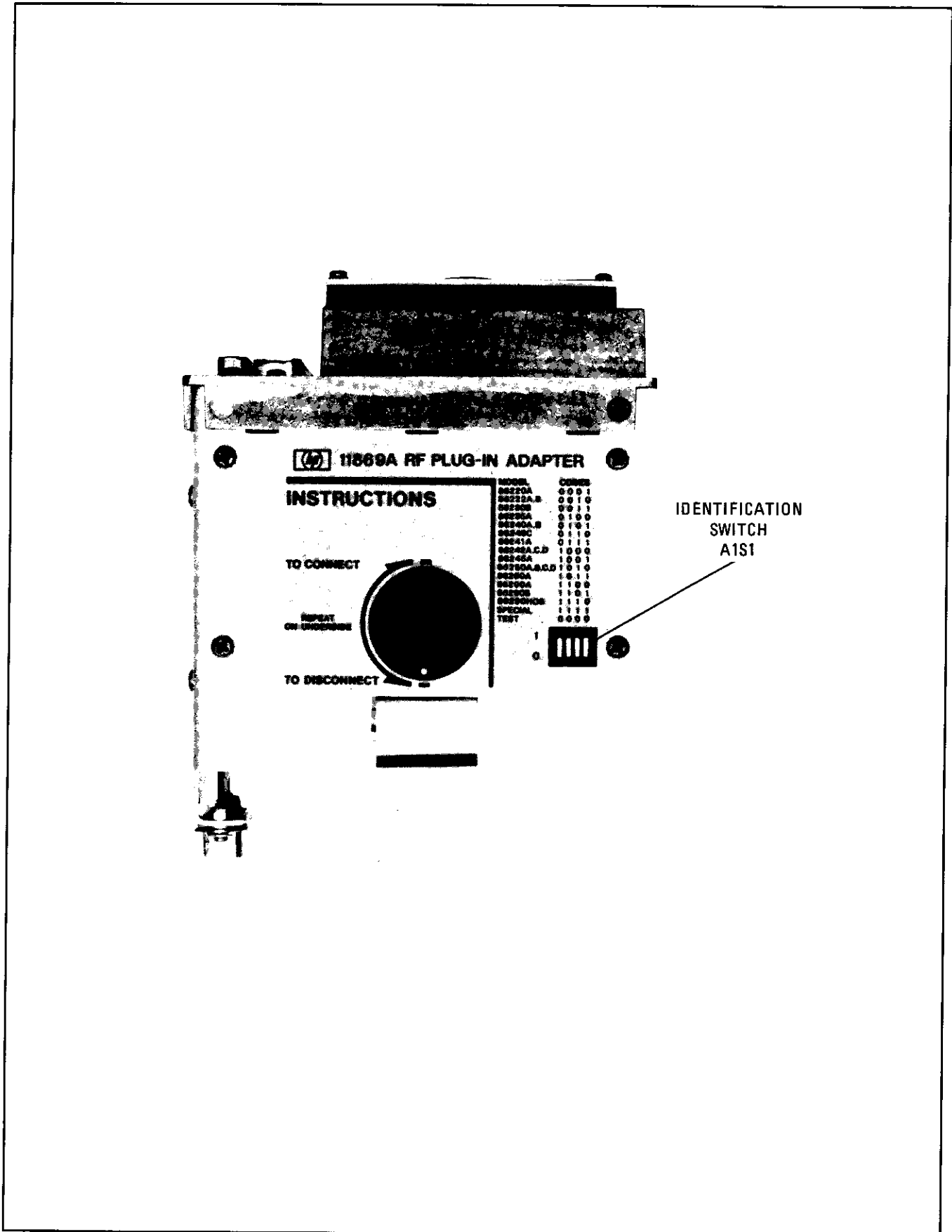

Figure 3-1. RF Plug-in Identification Switch A1S1

SECTION IV
PERFORMANCE TESTS

4-1. INTRODUCTION

4-2. The procedures in this section test the electrical performance of the model 11869A RF Plug-In Adapter. All tests can be performed without access to the interior of the instrument.

4-3. EQUIPMENT REQUIRED

4-4. The equipment required for the performance tests is listed in Table 1-2. Only the 86290A/B/C Plug-Ins will check the band changing function.

4-5. TEST RECORD

4-6. Results of the performance tests may be tabulated on the Performance Test Record (Table 4-1) at the end of this section.

4-7. PERFORMANCE TESTS

4-8. Self Test

- a. This test verifies the interconnections between the 8350A Mainframe and the 11869A Adapter. Connect the 11869A Adapter to the selected 86200 series Plug-In as described in Section II, and install this assembly into an 8350A Sweep Oscillator. (Selection of an 86290 RF Plug-In is preferred so that the multiband switching circuits in the 11869A can be checked.)
- b. Switch ON the LINE power to the 8350A. Switching on the line power or pressing the front panel INSTR PRESET button initiates a series of self-tests within the instrument, including one in the 11869A that checks the interconnections between the 8350A and the Adapter. If the 11869A Adapter is not making proper contact, the error message E001 will be displayed on the 8350A FREQUENCY readout.

4-9. Frequency Range

- a. When the line power is switched on or the 8350A INSTR PRESET button is pressed, the frequency range of the installed Plug-In should be displayed on the 8350A FREQUENCY readout. If an incorrect frequency range is displayed, check that the Plug-In Identification Switch AIS1 on the top panel of the 11869A is correctly coded to match the model number of the Plug-In.

4-10. CW and Manual Gate

- a. To test the 'CW AND MAN GATE' signal interface, perform the Residual FM test in CW mode as described in the Operating and Service Manual of the RF Plug-In in use. If the 'CW AND MAN GATE' signal from the 11869A is not correct, excessive residual FM noise will be present.

4-11. Multiband Operation (86290 Only)

- a. This test verifies that the sweep is stopped at the bandswitch points to enable a change to the next band. This test is performed only on the 86290A/B/C. Connect the equipment as shown in Figure 4-1, with the 1740A Oscilloscope in A vs B mode. (If a different model oscilloscope is used, externally sweep the scope with the 8350A SWEEP OUTPUT.) On the 8350A select a START frequency of 2 GHz, a STOP frequency of 18 GHz, and a fast sweep time. Set the 86290 for maximum leveled output power. If one or more of the bands has no power, suspect Output Latch U9 or Inverter U11A.
- b. If the band changing circuit is functioning correctly, bright spots of amplified intensity will appear at the bandswitch points (6.0 - 6.2 GHz and 12.0 - 12.4 GHz). If proper band switching does not occur, suspect the SEQ SYNC or L SSRQ (stop sweep request) signals from the 11869A Adapter.

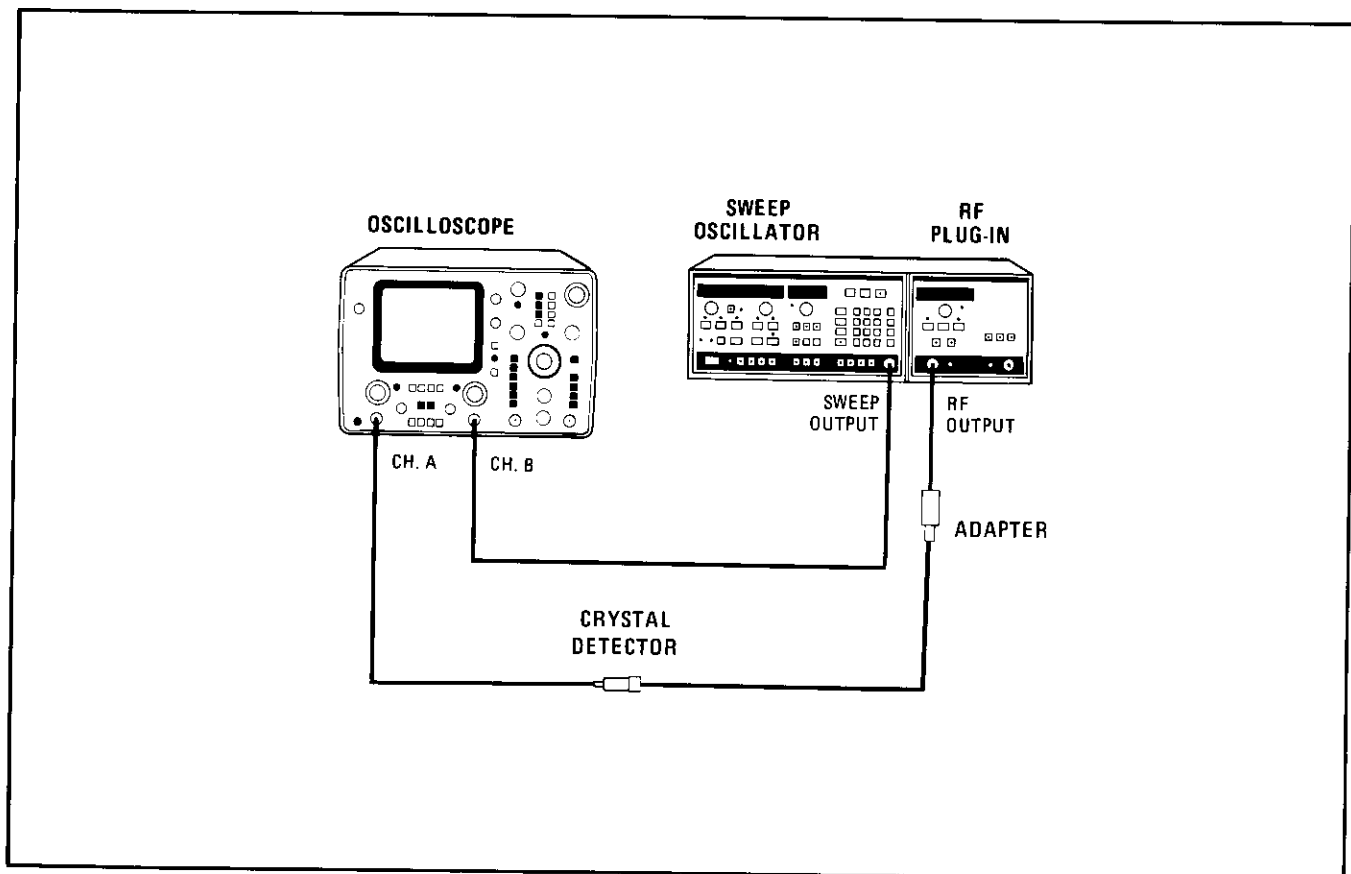
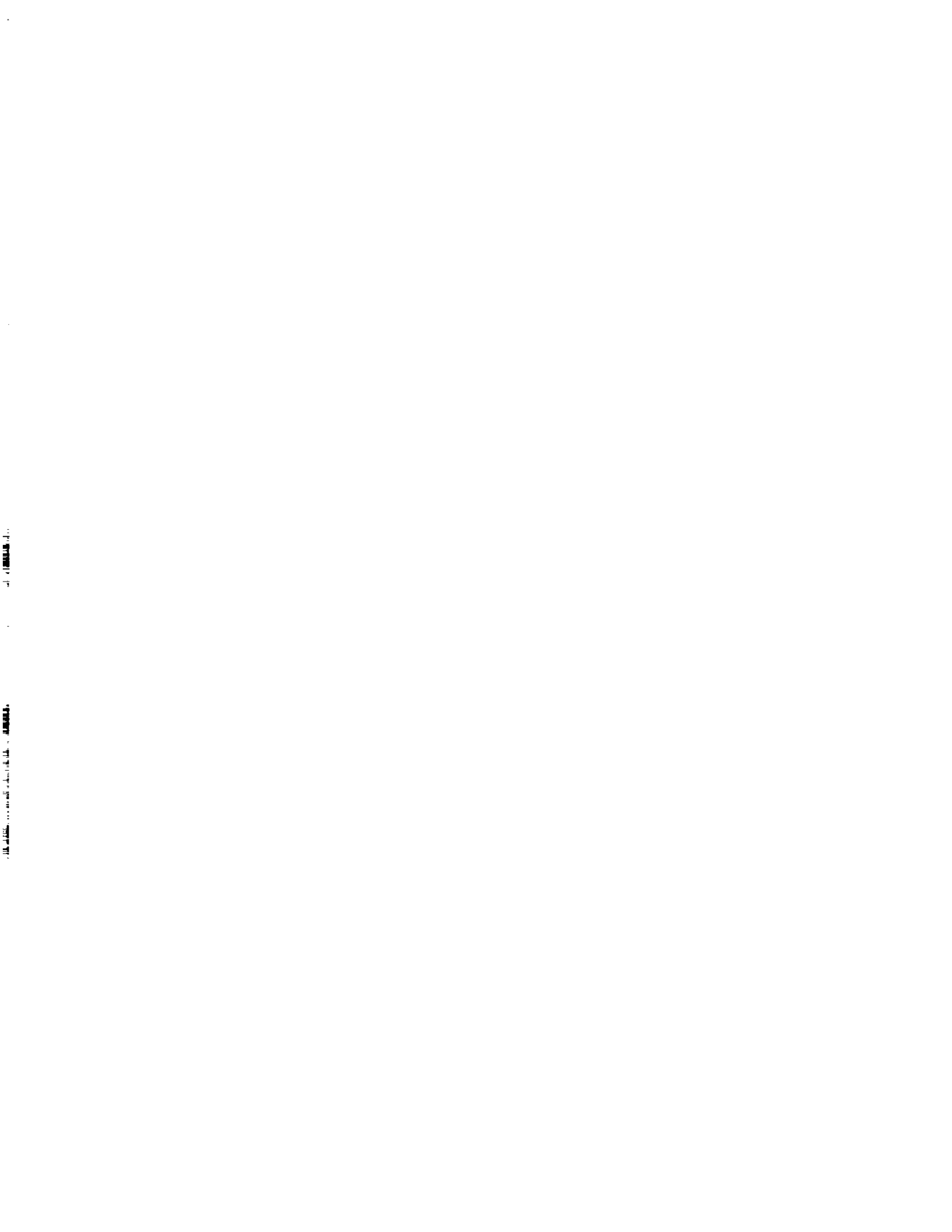

Figure 4-1. Test Setup for Multiband Operation

Table 4-1. Performance Test Record

Paragraph Number	Description	Problem	No Problem	Actual
4-8	Self-Test	E001	No Error Message	-
4-9	Frequency Range	Range does not match	Range matches Plug-In	-
4-10	CW and Manual Gate (Residual FM Test)	See RF Plug-In Manual	See RF Plug-In Manual	-
4-11	Multiband Operation (86290 Only)	No intensity spots or no output power	Intensity spots at bandswitch points	-



SECTION V
ADJUSTMENTS

5-1. INTRODUCTION

5-2. There are no electrical adjustments on the 11869A RF Plug-In Adapter.

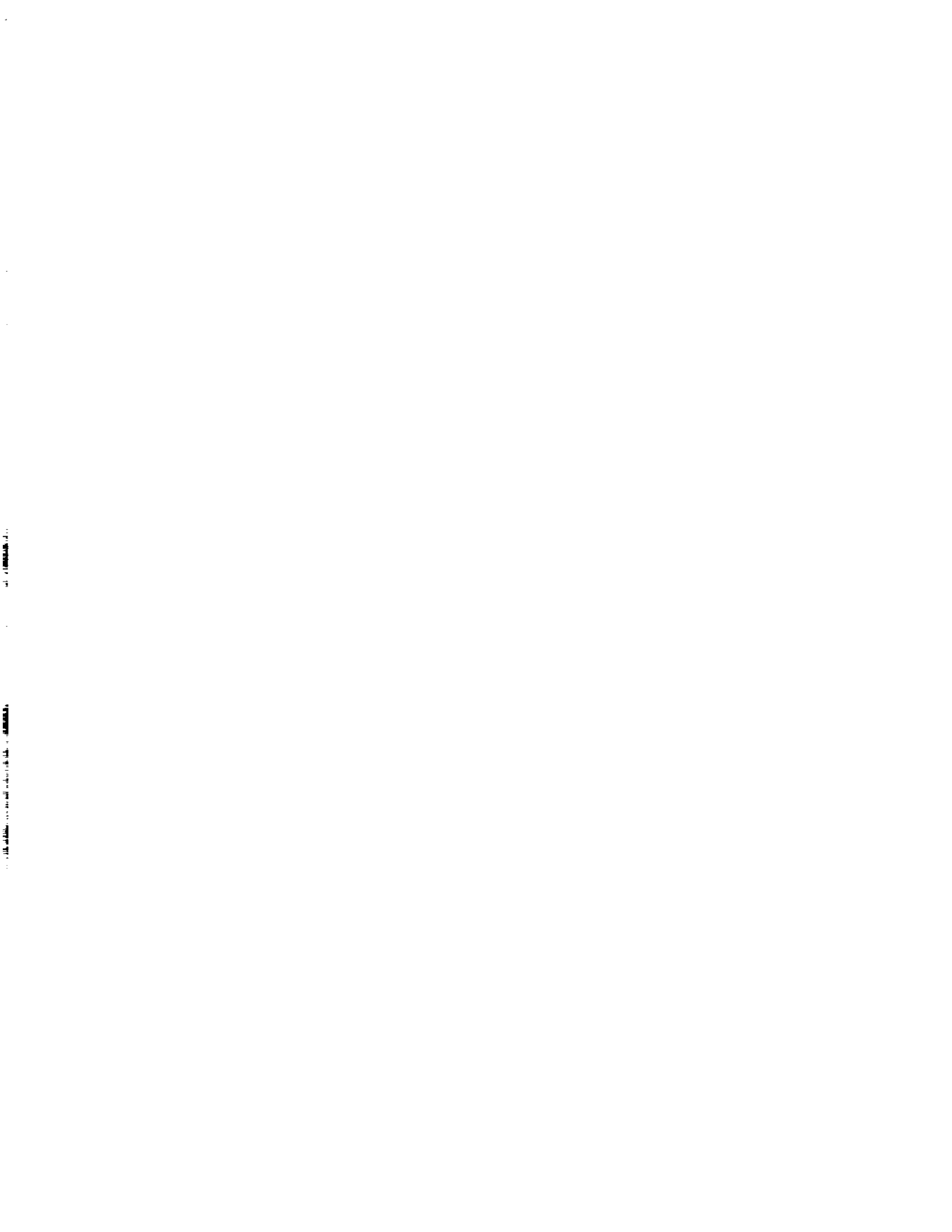

SECTION VI

REPLACEABLE PARTS

6-1. INTRODUCTION

6-2. This section contains information for ordering parts. Table 6-1 lists reference designators and abbreviations used in the parts list, and the names and addresses that correspond with the manufacturers' code numbers. Table 6-2 lists all replaceable parts in reference designator order.

WARNING

Any service or adjustment performed with the covers of the 8350A removed should only be performed by qualified service personnel. A shock hazard exists with the covers removed.

6-3. ABBREVIATIONS

6-4. Table 6-1 lists abbreviations used in the parts list and schematics. The abbreviations in the parts list are in capital letters. However, in the schematics, abbreviation forms with both lower case and upper case letters are used.

6-5. REPLACEABLE PARTS LIST

6-6. Table 6-2 is the list of replaceable parts and is organized as follows:

- a. Electrical assemblies and their components in alpha-numerical order by reference designation.
- b. Chassis-mounted parts in alpha-numerical order by reference designation.
- c. Miscellaneous parts.

6-7. The information given for each part consists of the following:

- a. The Hewlett-Packard part number.
- b. The part number check digit (CD).
- c. The total quantity (Qty) in the instrument.
- d. The description of the part.
- e. A typical manufacturer of the part in a five-digit code.
- f. The manufacturer's number for the part.

6-8. The total quantity for each part is given only once - at the first appearance of the part number in the list.

NOTE

Total quantities for optional assemblies are totaled by assembly and not integrated into the standard list.

6-9. ORDERING INFORMATION

6-10. To order a part listed in the replaceable parts table, quote the Hewlett-Packard part number (with the check digit), indicating the quantity required, and address the order to the nearest Hewlett-Packard Office. The check digit will ensure accurate and timely processing of your order.

6-11. To order a part that is not listed in the replaceable parts table, include the instrument model number, instrument serial number, description and function of the part, and the number of parts required. Address the order to the nearest Hewlett-Packard Office. For a list of Hewlett-Packard Offices, see inside the back cover of this Manual.

6-12. PROM U6 FOR SPECIAL RF PLUG-INS

6-13. Factory modified Special 86200 series Plug-Ins with non-standard frequency coverage (those not listed on the top panel of the 11869A) require a special PROM to be inserted into the 11869A Adapter in the socket AlXU6 on the Logic Board. To order a PROM for a factory modified Special Plug-In, contact your nearest HP Sales and Service Office.

Table 6-1. Reference Designations, Manufacturer Codes, and Abbreviations (1 of 2)

REFERENCE DESIGNATORS			
A	Assembly	Q	Transistor
C	Capacitor	R	Resistor
CR	Diode	S	Switch
J	Electrical Connector (Stationary Portion), Jack	TP	Test Point
L	Coil, Inductor	U	Integrated Circuit, Microcircuit
MP	Miscellaneous Mechanical Part	W	Cable, Transmission Path, Wire
P	Electrical Connector (Movable Portion), Plug	X	Socket

Table 6-1. Reference Designations, Manufacturer Codes, and Abbreviations (2 of 2)

MANUFACTURERS CODE LIST			
MFR. NO.	MANUFACTURER NAME	ADDRESS	ZIP CODE
00000	ANY SATISFACTORY SUPPLIER		
01295	TEXAS INSTR INC SEMICOND CMPNT DIV	DALLAS TX	75222
04713	MOTOROLA SEMICONDUCTOR PRODUCTS	PHOENIX AZ	85062
06001	GE CO ELEK CAP & BAT PROD DEPT	IRMO SC	29063
11236	CTS OF BERNE INC	BERNE IN	46711
24546	CORNING GLASS WORKS (BRADFORD)	BRADFORD PA	16701
28480	HEWLETT-PACKARD CO CORPORATE HQ	PALO ALTO CA	94304
56289	SPRAGUE ELECTRIC CO	NORTH ADAMS MA	01247
11869A ABBREVIATIONS			
A	Address, Ampere, Assembly	LG	Long
AL	Aluminum	LKG	Locking
ALC	Automatic Leveling Circuit	LS	Low-Power Schottky
AM	Amplitude Modulated, Amplitude Modulation	M	Male, Mega, Milli
ASSY	Assembly	MA	Milliampere
BFR	Buffer	MACH	Machined
BRS	Brass	MTLC	Metallic
CER	Ceramic	OCTL	Octal
COM	Commercial, Common	OPT	Option
CONT	Contact	PC	Printed Circuit
CW	Clockwise, Continuous Wave	PD	Power Dissipation
D	Data, Delay, Diameter	PLSTC	Plastic
DCCR	Decoder	POS	Positive
DEG	Degree	POZI	Pozidriv Recess
DIP	Dual In-Line Package	PRP	Purpose
DR	Drive	RES	Resistor
DRVR	Driver	RF	Radio Frequency
EN	Enable	RKR	Rocker
EXT	External	RVT	Rivet, Riveted
F	Female, Filtered, Fixed	SI	Silicon
FF	Flip-Flop, Latch	SLDR	Solder
FL	Flat	STL	Steel
FM	Frequency Modulated, Frequency Modulation	TA	Tantalum
FXD	Fixed	TC	Temperature Coefficient
GEN	General	THD	Thread, Threaded
HD	Head	THK	Thick
HEX	Hexadecimal, Hexagonal, Six to a Package	TRIG	Trigger, Triggered
HZ	Hertz	TTL	Transistor-Transistor Logic
IC	Integrated Circuit	UF	Microfarad
ID	Inside Diameter	UNMTD	Unmated
IN	Inch	V	Volts
INP	Input	VDC	Volts (Direct Current)
INV	Inverter	VF	Volts (Filtered)
K	Kilo, Kilo-Ohm, Thousand	W	Watt, Wire, Cable, Cable Assembly

Table 6-3. Replaceable Parts

Reference Designation	HP Part Number	C D	Qty	Description	Mfr Code	Mfr Part Number
A1	11869-60010	6	1	BOARD ASSEMBLY-LOGIC	28480	11869-60010
A1C1	0180-0058	0	1	CAPACITOR-FXD 50UF+75-10% 25VDC AL	56289	30D506G025CC2
A1C2	0160-2055	9	13	CAPACITOR-FXD .01UF +80-20% 100VDC CER	28480	0160-2055
A1C3	0160-2055	9		CAPACITOR-FXD .01UF +80-20% 100VDC CER	28480	0160-2055
A1C4	0160-2055	9		CAPACITOR-FXD .01UF +80-20% 100VDC CER	28480	0160-2055
A1C5	0160-2055	9		CAPACITOR-FXD .01UF +80-20% 100VDC CER	28480	0160-2055
A1C6	0160-2055	9		CAPACITOR-FXD .01UF +80-20% 100VDC CER	28480	0160-2055
A1C7	0160-2055	9		CAPACITOR-FXD .01UF +80-20% 100VDC CER	28480	0160-2055
A1C8	0160-2055	9		CAPACITOR-FXD .01UF +80-20% 100VDC CER	28480	0160-2055
A1C9	0160-2055	9		CAPACITOR-FXD .01UF +80-20% 100VDC CER	28480	0160-2055
A1C10	0160-2055	9		CAPACITOR-FXD .01UF +80-20% 100VDC CER	28480	0160-2055
A1C11	0160-2055	9		CAPACITOR-FXD .01UF +80-20% 100VDC CER	28480	0160-2055
A1C12	0160-2055	9		CAPACITOR-FXD .01UF +80-20% 100VDC CER	28480	0160-2055
A1J1	1251-5902	5	1	CONNECTOR 32-PIN M POST TYPE	28480	1251-5902
A1J2	1200-0507	9	3	SOCKET-IC 16-CONT DIP-SLDR	28480	1200-0507
A1L1	08503-80001	9	1	COIL-TOROID	28480	08503-80001
A1MP1	0380-0111	0	4	STANDOFF-RVT-ON .25-IN-LG 6-32THD	00000	ORDER BY DESCRIPTION
A1MP2	0380-0111	0		STANDOFF-RVT-ON .25-IN-LG 6-32THD	00000	ORDER BY DESCRIPTION
A1MP3	0380-0111	0		STANDOFF-RVT-ON .25-IN-LG 6-32THD	00000	ORDER BY DESCRIPTION
A1MP4	0380-0111	0		STANDOFF-RVT-ON .25-IN-LG 6-32THD	00000	ORDER BY DESCRIPTION
A1R1	0757-0442	9	11	RESISTOR 10K 1% .125W F TC=0+100	24546	C4-1/8-T0-1002-F
A1R2	0757-0442	9		RESISTOR 10K 1% .125W F TC=0+100	24546	C4-1/8-T0-1002-F
A1R3	0757-0442	9		RESISTOR 10K 1% .125W F TC=0+100	24546	C4-1/8-T0-1002-F
A1R4	0757-0442	9		RESISTOR 10K 1% .125W F TC=0+100	24546	C4-1/8-T0-1002-F
A1R5	0757-0442	9		RESISTOR 10K 1% .125W F TC=0+100	24546	C4-1/8-T0-1002-F
A1R6	0757-0442	9		RESISTOR 10K 1% .125W F TC=0+100	24546	C4-1/8-T0-1002-F
A1S1	3101-2063	8	1	SWITCH-RKR DIP-RKR-ASSY 4-1A .05A 30VDC	28480	3101-2063
A1U1	1820-1216	3	1	IC DCR TTL LS 3-TO-8-LINE 3-INP	01295	SN74LS138N
A1U2	1820-1416	5	2	IC SCHMITT-TRIG TTL LS INV HEX 1-INP	01295	SN74LS14N
A1U3	1820-1416	5		IC SCHMITT-TRIG TTL LS INV HEX 1-INP	01295	SN74LS14N
A1U4	1810-0338	7	1	NETWORK-RES 16-DIP100.0 OHM X 8	11236	761-3-R100
A1U5	1820-1491	6	1	IC BFR TTL LS NON-INV HEX 1-INP	01295	SN74LS367AN
A1U6				SEE PARAGRAPH 6-12		
A1U7	1820-2075	4	1	IC MISC TTL LS	01295	SN74LS245N
A1U8	1820-1198	0	1	IC GATE TTL LS NAND QUAD 2-INP	01295	SN74LS03N
A1U9	1820-1730	6	2	IC FF TTL LS D-TYPE POS-EDGE-TRIG COM	01295	SN74LS273N
A1U10	1820-1730	6		IC FF TTL LS D-TYPE POS-EDGE-TRIG COM	01295	SN74LS273N
A1U11	1820-1917	1	1	IC BFR TTL LS LINE DRVR OCTL	01295	SN74LS240N
A1U12	1820-2024	3	1	IC DRVR TTL LS LINE DRVR OCTL	01295	SN74LS244N
A1XU6	1200-0507	9		SOCKET-IC 16-CONT DIP-SLDR	28480	1200-0507
A2	11869-60023	1	1	BOARD ASSEMBLY-CONNECTOR	28480	11869-60023
A2C1	0160-2055	9		CAPACITOR-FXD .01UF +80-20% 100VDC CER	28480	0160-2055
A2C2	0160-2055	9		CAPACITOR-FXD .01UF +80-20% 100VDC CER	28480	0160-2055
A2C3	0180-0269	5	1	CAPACITOR-FXD 1UF+50-10% 150VDC AL	56289	30D105G150RA2
A2C4	0180-0291	3	1	CAPACITOR-FXD 1UF+10% 35VDC TA	56289	150D105X9035A2
A2C5	0180-2338	3	1	CAPACITOR-FXD 650UF+20% 13VDC TA	06001	69F2330G7
A2CR1	1901-0033	2	2	DIODE-GEN PRP 180V 200MA DO-7	28480	1901-0033
A2CR2	1901-0033	2		DIODE-GEN PRP 180V 200MA DO-7	28480	1901-0033
A2J1	1200-0507	9		SOCKET-IC 16-CONT DIP-SLDR	28480	1200-0507
A2J2	1250-0257	1	2	CONNECTOR-RF SMR M PC 50-OHM	28480	1250-0257
A2J3	1250-0257	1		CONNECTOR-RF SMR M PC 50-OHM	28480	1250-0257
A2J4	1251-4740	7	1	CONNECTOR 14-PIN M POST TYPE	28480	1251-4740
A2MP1	0380-0600	2	3	STANDOFF-RVT-ON .219-IN-LG 6-32THD	00000	ORDER BY DESCRIPTION
A2MP2	0380-0600	2		STANDOFF-RVT-ON .219-IN-LG 6-32THD	00000	ORDER BY DESCRIPTION
A2MP3	0380-0600	2		STANDOFF-RVT-ON .219-IN-LG 6-32THD	00000	ORDER BY DESCRIPTION
A2Q1	1854-0477	7	2	TRANSISTOR NPN 2N2222A SI TO-18 PD=500MW	04713	2N2222A
A2Q2	1854-0477	7		TRANSISTOR NPN 2N2222A SI TO-18 PD=500MW	04713	2N2222A
A2Q3	1853-0281	9	1	TRANSISTOR PNP 2N2907A SI TO-18 PD=400MW	04713	2N2907A
A2R1	0757-0442	9		RESISTOR 10K 1% .125W F TC=0+100	24546	C4-1/8-T0-1002-F
A2R2	0757-0442	9		RESISTOR 10K 1% .125W F TC=0+100	24546	C4-1/8-T0-1002-F
A2R3	0757-0442	9		RESISTOR 10K 1% .125W F TC=0+100	24546	C4-1/8-T0-1002-F
A2R4	0757-0442	9		RESISTOR 10K 1% .125W F TC=0+100	24546	C4-1/8-T0-1002-F
A2R5	0757-0442	9		RESISTOR 10K 1% .125W F TC=0+100	24546	C4-1/8-T0-1002-F
A2R6	0757-0463	4	1	RESISTOR 82.5K 1% .125W F TC=0+100	24546	C4-1/8-T0-8252-F
A2R7	0757-0276	7	1	RESISTOR 61.9 1% .125W F TC=0+100	24546	C4-1/8-T0-61R9-F
A2R8	0757-0421	4	1	RESISTOR 825 1% .125W F TC=0+100	24546	C4-1/8-T0-825R-F
A2R9	0757-0280	3	1	RESISTOR 1K 1% .125W F TC=0+100	24546	C4-1/8-T0-1001-F

See introduction to this section for ordering information
 *Indicates factory selected value

Table 6-3. Replaceable Parts

Reference Designation	HP Part Number	C D	Qty	Description	Mfr Code	Mfr Part Number
A2S1	3101-2419	8	1	SWITCH-SL DPDT SUBMIN .5A 125VAC PC	28480	3101-2419
MP1	0361-1088	2	4	RIVET-NYLON SLIDE BLIND DR PIN	28480	0361-1088
MP2	0361-1088	2		RIVET-NYLON SLIDE BLIND DR PIN	28480	0361-1088
MP3	0361-1088	2		RIVET-NYLON SLIDE BLIND DR PIN	28480	0361-1088
MP4	0361-1088	2		RIVET-NYLON SLIDE BLIND DR PIN	28480	0361-1088
MP5	7121-0551	1	1	LABEL-TOP 2.8-IN-WD 3.65-IN-LG	28480	7121-0551
MP6	11869-40001	3	2	ADAPTER KNOB	28480	11869-40001
MP7	11869-40001	3		ADAPTER KNOB	28480	11869-40001
MP8	11869-00002	0	2	CLIP-MOUNTING	28480	11869-00002
MP9	11869-00002	0		CLIP-MOUNTING	28480	11869-00002
MP10	2360-0117	6	11	SCREW-MACH 6-32 .375-IN-LG PAN-HD-POZI	00000	ORDER BY DESCRIPTION
MP11	2360-0117	6		SCREW-MACH 6-32 .375-IN-LG PAN-HD-POZI	00000	ORDER BY DESCRIPTION
MP12	2360-0117	6		SCREW-MACH 6-32 .375-IN-LG PAN-HD-POZI	00000	ORDER BY DESCRIPTION
MP13	2360-0117	6		SCREW-MACH 6-32 .375-IN-LG PAN-HD-POZI	00000	ORDER BY DESCRIPTION
MP14	2360-0117	6		SCREW-MACH 6-32 .375-IN-LG PAN-HD-POZI	00000	ORDER BY DESCRIPTION
MP15	2360-0117	6		SCREW-MACH 6-32 .375-IN-LG PAN-HD-POZI	00000	ORDER BY DESCRIPTION
MP16	2360-0117	6		SCREW-MACH 6-32 .375-IN-LG PAN-HD-POZI	00000	ORDER BY DESCRIPTION
MP17	2360-0117	6		SCREW-MACH 6-32 .375-IN-LG PAN-HD-POZI	00000	ORDER BY DESCRIPTION
MP18	2360-0117	6		SCREW-MACH 6-32 .375-IN-LG PAN-HD-POZI	00000	ORDER BY DESCRIPTION
MP19	2360-0117	6		SCREW-MACH 6-32 .375-IN-LG PAN-HD-POZI	00000	ORDER BY DESCRIPTION
MP20	2360-0117	6		SCREW-MACH 6-32 .375-IN-LG PAN-HD-POZI	00000	ORDER BY DESCRIPTION
MP21	3050-0227	3	4	WASHER-FL MTLK NO. 6 .149-IN-ID	28480	3050-0227
MP22	3050-0227	3		WASHER-FL MTLK NO. 6 .149-IN-ID	28480	3050-0227
MP23	3050-0227	3		WASHER-FL MTLK NO. 6 .149-IN-ID	28480	3050-0227
MP24	3050-0227	3		WASHER-FL MTLK NO. 6 .149-IN-ID	28480	3050-0227
MP25	11869-00004	2	1	SLIDE-ADAPTER	28480	11869-00004
MP26	6960-0001	3	4	PLUG-HOLE DOME-HD FOR .375-D-HOLE STL	28480	6960-0001
MP27	6960-0001	3		PLUG-HOLE DOME-HD FOR .375-D-HOLE STL	28480	6960-0001
MP28	6960-0001	3		PLUG-HOLE DOME-HD FOR .375-D-HOLE STL	28480	6960-0001
MP29	6960-0001	3		PLUG-HOLE DOME-HD FOR .375-D-HOLE STL	28480	6960-0001
MP30	6960-0046	6	1	PLUG-HOLE DOME-HD FOR .688-D-HOLE BRS	28480	6960-0046
MP31	2200-0107	6	4	SCREW-MACH 4-40 .375-IN-LG PAN-HD-POZI	00000	ORDER BY DESCRIPTION
MP32	2200-0107	6		SCREW-MACH 4-40 .375-IN-LG PAN-HD-POZI	00000	ORDER BY DESCRIPTION
MP33	2200-0107	6		SCREW-MACH 4-40 .375-IN-LG PAN-HD-POZI	00000	ORDER BY DESCRIPTION
MP34	2200-0107	6		SCREW-MACH 4-40 .375-IN-LG PAN-HD-POZI	00000	ORDER BY DESCRIPTION
MP35	0590-0076	1	4	NUT-HEX-PLSTC LKG 4-40-THD .143-IN-THK	28480	0590-0076
MP36	0590-0076	1		NUT-HEX-PLSTC LKG 4-40-THD .143-IN-THK	28480	0590-0076
MP37	0590-0076	1		NUT-HEX-PLSTC LKG 4-40-THD .143-IN-THK	28480	0590-0076
MP38	0590-0076	1		NUT-HEX-PLSTC LKG 4-40-THD .143-IN-THK	28480	0590-0076
MP39	11869-00003	1	1	PANEL-REAR	28480	11869-00003
MP40	0050-2032	9	1	CASTING-ALUMINUM REAR FRAME	28480	0050-2032
MP41	2200-0105	4	4	SCREW-MACH 4-40 .312-IN-LG PAN-HD-POZI	00000	ORDER BY DESCRIPTION
MP42	2200-0105	4		SCREW-MACH 4-40 .312-IN-LG PAN-HD-POZI	00000	ORDER BY DESCRIPTION
MP43	2200-0105	4		SCREW-MACH 4-40 .312-IN-LG PAN-HD-POZI	00000	ORDER BY DESCRIPTION
MP44	2200-0105	4		SCREW-MACH 4-40 .312-IN-LG PAN-HD-POZI	00000	ORDER BY DESCRIPTION
MP45	7120-2359	9	1	LABEL-SERIAL .625-IN-WD 1.5-IN-LG AL	28480	7120-2359
MP46	2360-0181	4	4	SCREW-MACH 6-32 .25-IN-LG 82 DEG	00000	ORDER BY DESCRIPTION
MP47	2360-0181	4		SCREW-MACH 6-32 .25-IN-LG 82 DEG	00000	ORDER BY DESCRIPTION
MP48	2360-0181	4		SCREW-MACH 6-32 .25-IN-LG 82 DEG	00000	ORDER BY DESCRIPTION
MP49	2360-0181	4		SCREW-MACH 6-32 .25-IN-LG 82 DEG	00000	ORDER BY DESCRIPTION
MP50	11869-00001	9	1	DECK-ADAPTER	28480	11869-00001
MP51	0590-0106	8	2	NUT-HEX-PLSTC LKG 2-56-THD .143-IN-THK	00000	ORDER BY DESCRIPTION
MP52	3050-0098	6	4	WASHER-FL MTLK NO. 2 .094-IN-ID	28480	3050-0098
MP53	3050-0098	6		WASHER-FL MTLK NO. 2 .094-IN-ID	28480	3050-0098
MP54	3050-0098	6		WASHER-FL MTLK NO. 2 .094-IN-ID	28480	3050-0098
MP55	3050-0098	6		WASHER-FL MTLK NO. 2 .094-IN-ID	28480	3050-0098
MP56	0520-0130	1	2	SCREW-MACH 2-56 .375-IN-LG PAN-HD-POZI	00000	ORDER BY DESCRIPTION
MP57	0520-0130	1		SCREW-MACH 2-56 .375-IN-LG PAN-HD-POZI	00000	ORDER BY DESCRIPTION
MP58	0590-0106	8		NUT-HEX-PLSTC LKG 2-56-THD .143-IN-THK	00000	ORDER BY DESCRIPTION
MP59	7121-1050	7	1	LABEL-BOTTOM .85-IN-WD 2.92-IN-LG	28480	7121-1050
MP60	5021-0906	6	2	SLEEVE-RF PIN POS	28480	5021-0906
MP61	5021-0906	6		SLEEVE-RF PIN POS	28480	5021-0906
MP62	11869-20020	4	1	CONNECTOR ALIGNMENT PIN	28480	11869-20020
MP63	0510-0089	3	1	RETAINER-RING BSC EXT .188-IN-DIA BE-CU	28480	0510-0089
MP64	1400-0937	8	1	CLIP-CMPNT 1.485-.515-DIA SPR-STL	86928	4521-50-30-2C
MP65	0361-0512	5	1	RIVET SEMI-TUB 100-FLH .123DIA .156LG	28480	0361-0512
P1	1251-0484	8	1	CONNECTOR 36-PIN F MICRO RIBBON	28480	1251-0484
P2	1251-3502	7	1	CONNECTOR 21-PIN M D SERIES	28480	1251-3502
P3	1251-5901	4	1	CONNECTOR 64-PIN M MICRO RIBBON	28480	1251-5901
W1	11869-60001	5	1	CABLE ASSEMBLY 16-RIBBON	28480	11869-60001
W1P1	1251-2615	1	2	CONNECTOR 16-PIN M RECTANGULAR	28480	1251-2615
W1P2	1251-2615	1		CONNECTOR 16-PIN M RECTANGULAR	28480	1251-2615

See introduction to this section for ordering information
 *Indicates factory selected value

Table 6-3. Replaceable Parts

Reference Designation	HP Part Number	C D	Qty	Description	Mfr Code	Mfr Part Number
W2	11869-60017	3	1	CABLE ASSEMBLY 64-RIBBON (INCLUDES P3)	28480	11869-60017
W2P1	1251-5899	9	1	CONNECTOR 64-PIN F POST TYPE	28480	1251-5899
W3	11869-60003	7	1	COAX CABLE-BROWN (VTUNE)	28480	11869-60003
W4	11869-60004	8	1	CABLE ASSEMBLY 17-PIN (INCLUDES P2)	28480	11869-60004
W4P1	1251-4050	2	1	CONNECTOR 15-PIN F POST TYPE	28480	1251-4050
	1251-3967	8	1	CONTACT-CONN U/W-POST-TYPE FEM CRP	28480	1251-3967
	1251-3963	4	1	KEY-POST CONN	28480	1251-3963
W5	11869-60005	9	1	COAX CABLE-YELLOW (AM INPUT)	28480	11869-60005
W6	11869-60012	8	1	COAX CABLE-BLUE (FREQ REF)	28480	11869-60012
W7	11869-60013	9	1	COAX CABLE-VIOLET (FM INPUT)	28480	11869-60013
W8	11869-60014	0	1	COAX CABLE-GRAY (PULSE IN)	28480	11869-60014
W9	11869-60015	1	1	COAX CABLE-INSULATED (WHITE) (EXT ALC INPUT)	28480	11869-60015
W10	11869-20002	2		RF CABLE-REAR OUTPUT (OPT 004) (ALL EXCEPT 86290 AND 86251)	28480	11869-20002
W11	11869-20003	3		RF CABLE-REAR OUTPUT (OPT 004) (86290 AND 86251)	28480	11869-20003
W12	11869-20025	9		AUX OUT CABLE (OPT 006)	28480	11869-20025
	11869-60006	0	1	ADAPTER KIT (INCLUDES LATCH ACCESSORY KIT AND CABLES W6, W7, W8, W9)	28480	11869-60006
	11869-60007	1	1	LATCH ACCESSORY KIT (INCLUDES THE FOLLOWING)	28480	11869-60007
	1460-1186	2	1	SPRING BLK OXD	28480	1460-1186
	08621-20052	7	1	SCREW LATCH	28480	08621-20052
	11869-20001	1	1	LATCH-ADAPTER	28480	11869-20001
	3050-0001	1	1	WASHER-FL MTLN NO. 8 .172-IN-ID	28480	3050-0001
	11869-60009	3	1	BOARD REPLACEMENT KIT (INCLUDES A1, A2, W1, W2, W3, W4, AND W5)	28480	11869-60009
	11869-60024	2	1	CABLE REPLACEMENT KIT (INCLUDES W3, W4, W5)	28480	11869-60024
	11869-60008	2	1	CABLE KIT-OPTION 004 (INCLUDES THE FOLLOWING)	28480	11869-60008
W10	11869-20002	2	2	RF CABLE-REAR OUTPUT (OPT 004) (ALL EXCEPT 86290 AND 86251)	28480	11869-20002
W11	11869-20003	3	2	RF CABLE-REAR OUTPUT (OPT 004) (86290 AND 86251)	28480	11869-20003
J1	86290-60005	7	2	CONNECTOR ASSEMBLY TYPE N (RF OUTPUT)	28480	86290-60005
				CABLE KIT-OPTION 006 (INCLUDES THE FOLLOWING)		
W12	11869-20025	9	2	AUX OUT CABLE (OPT 006)	28480	11869-20025
J2	86290-60005	7		CONNECTOR ASSEMBLY TYPE N (AUX OUT)	28480	86290-60005

See introduction to this section for ordering information
*Indicates factory selected value

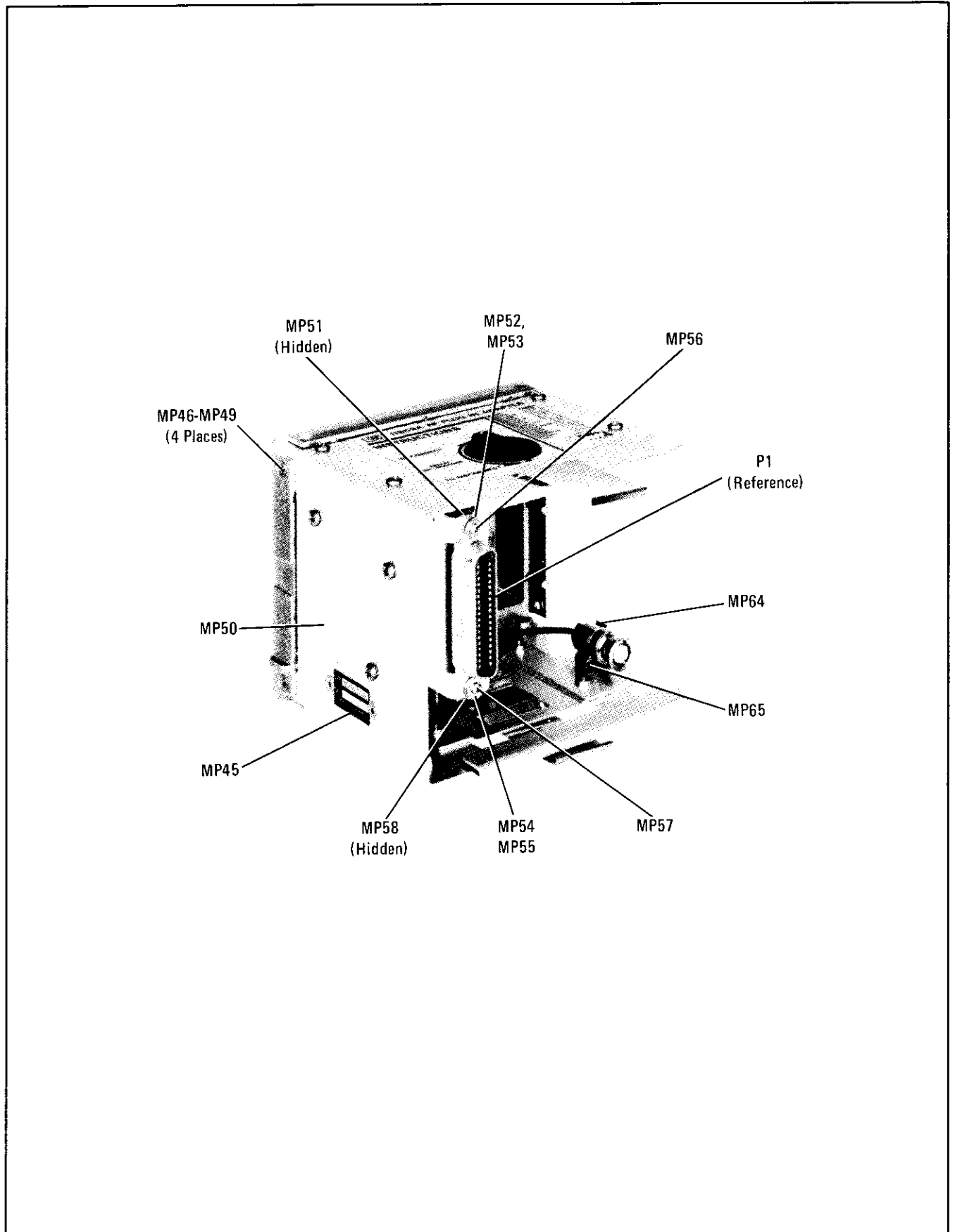

Figure 6-1. Mechanical Parts (1 of 2)

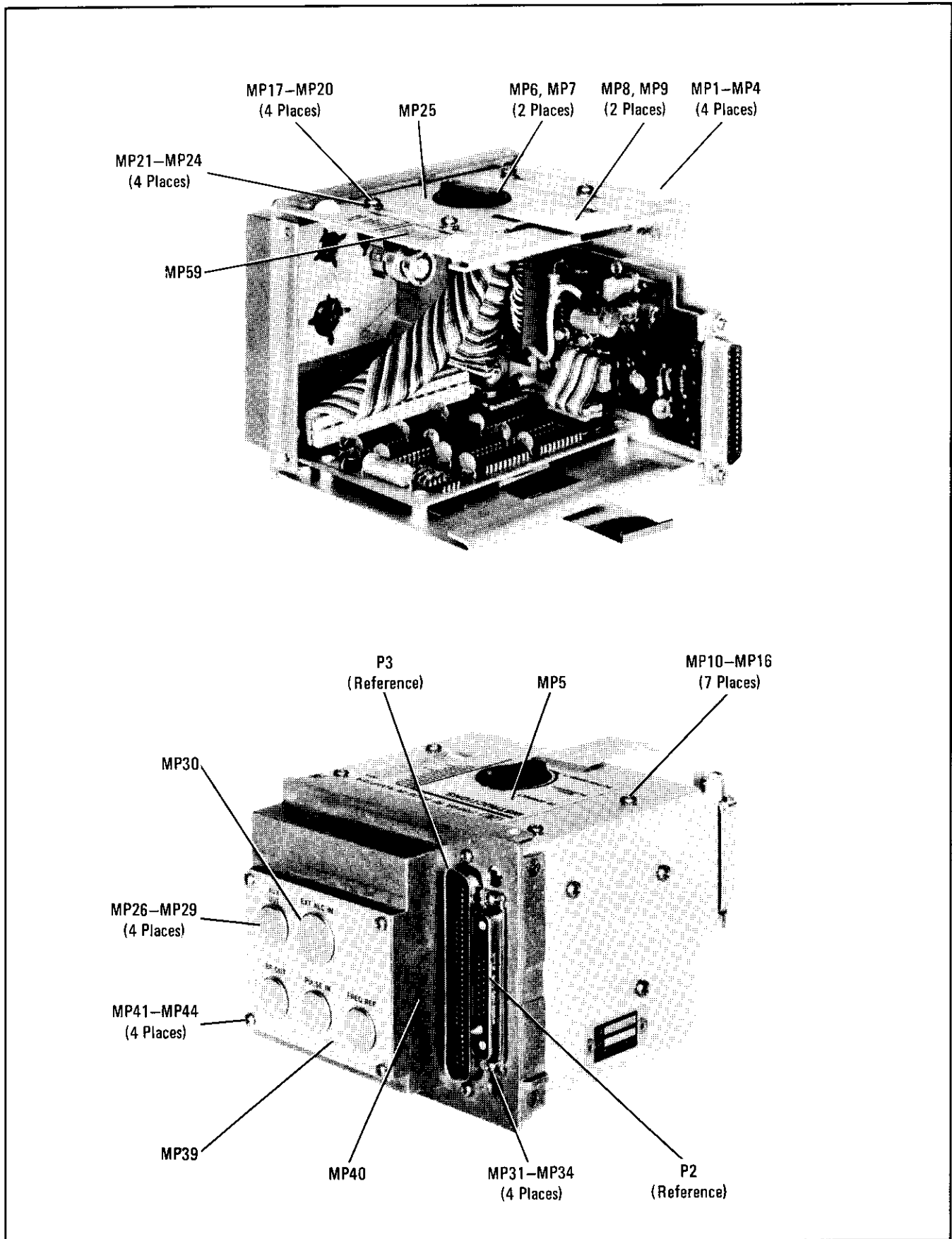
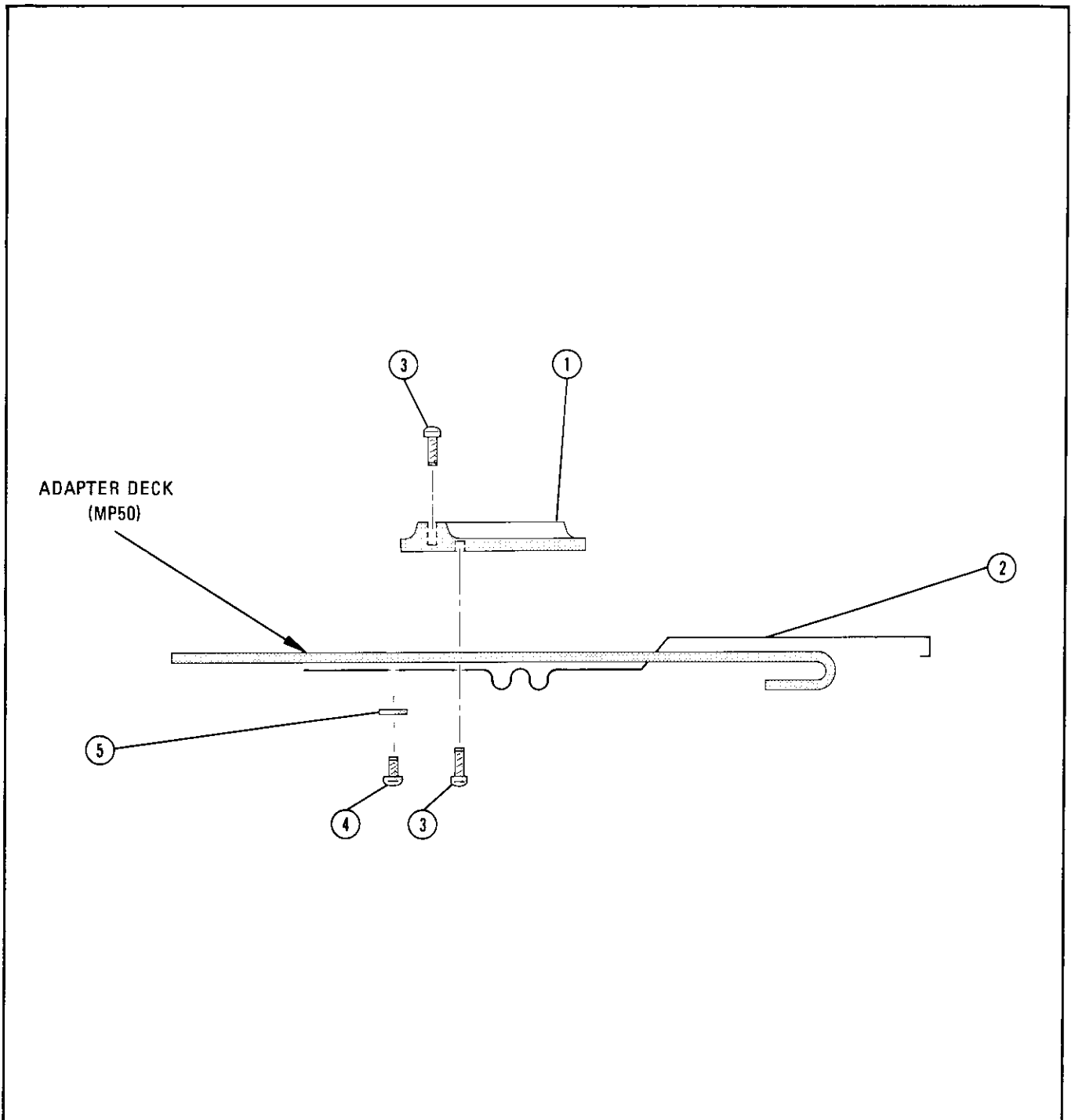
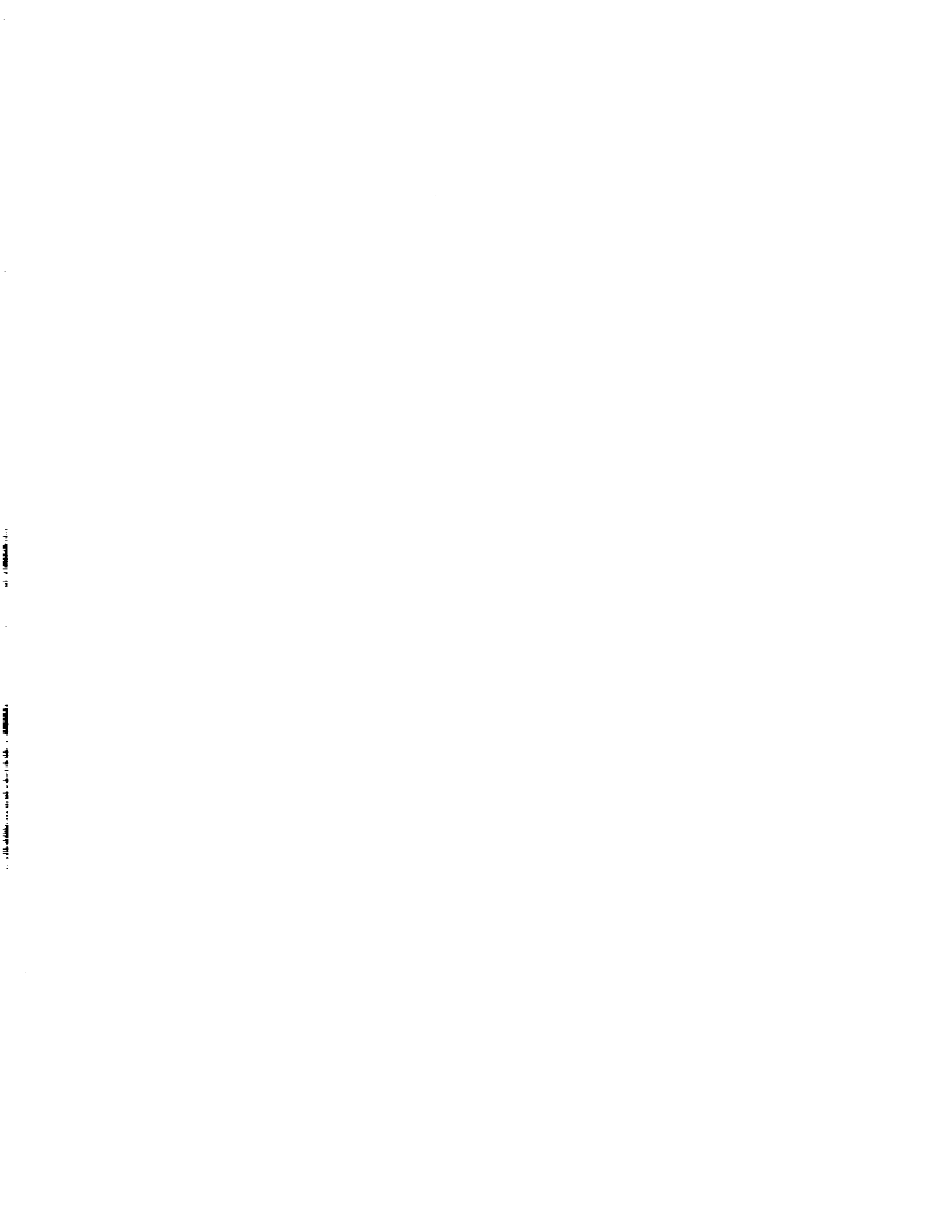

Figure 6-1. Mechanical Parts (2 of 2)



Ref. Desig.	HP Part Number	CD	Qty	Description
1	11869-40001	3	2	Adapter Knob
2	11869-00002	0	2	Clip, Mounting
3	3040-0006	5	4	SCREW-DR 0.188-IN-LG RD-HD SST-300
4	3040-0005	4	2	SCREW-DR 0.125-IN-LG RD-HD SST-300
5	3050-0079	3	2	WASHER-FL NM NO.2 .094-IN-ID .188-IN-OD

Figure 6-2. Mounting Clip and Knob Illustrated Parts Identification



SECTION VII
MANUAL BACKDATING CHANGES

7-1. INTRODUCTION

7-2. This manual has been written for and applies directly to instruments with serial numbers prefixed as indicated on the title page. Earlier versions of the instrument (serial numbers prefixed lower than the ones indicated on the title page) may be slightly different in design or appearance. The purpose of this section of the manual is to document these differences.

7-3. With the information provided in this section, this manual can be corrected so that it applies to any earlier version or configuration of the instrument. Later versions of the instrument (serial numbers prefixed higher than the ones indicated on the title page) will be documented in a yellow Manual Changes supplement.

7-4. To adapt this manual to an earlier instrument, refer to Table 7-1 and make all of the manual backdating changes listed opposite your instrument serial number or serial number prefix. Perform these changes in the alphabetical sequence listed.

7-5. For additional important information about serial number coverage, refer to INSTRUMENTS COVERED BY THE MANUAL in Section I.

Table 7-1. Manual Backdating Changes by Serial Number Prefix

Serial Prefix	Make Manual Changes
2142A & 2203A	A
2140A	A and B
2115A	A, B, and C
2105A	A, B, C, and D

7-6. MANUAL CHANGE INSTRUCTIONS**CHANGE A**

Page 1-0, Figure 1-1:

Replace the photograph of the 11869A RF Plug-In Adapter with the **11869A RF Plug-In Adapter (CHANGE A)** photograph in this section.

Delete the **OPTION 006 AUX OUT CONNECTOR AND CABLE** photograph.
Delete the words 'Factory Installed' adjacent to the FM INPUT cable.

Page 1-1, Paragraph 1-2:
Delete the last sentence.

Page 1-3, Table 1-1:
Delete the paragraph headed **Option 006 (Rear-Panel AUX OUT Connector)**.
In the paragraph headed **Rear Panel Description**, change the first part of the last sentence to read 'A BNC-to-SMD cable is supplied. . .'

Page 1-4, Table 1-1:
In the paragraph headed **Furnished**, delete the words 'factory installed'.

Page 2-9, Figure 2-5:
Delete Item 7, **Option 006: Connecting the AUX OUT Cable**.

Page 2-10, Figure 2-5.
In Item 8, **Mating the Adapter to the Plug-In**, delete 'or an Option 006 rear panel auxiliary output cable'.
In the first paragraph of Item 9, **Connecting the BNC Cables**, delete the last sentence, and replace the first sentence with the following:
'Four interconnect cables are supplied in a separate package with the 11869A. The purple BNC to SMD cable is the FM INPUT cable.'
At the beginning of the second paragraph of Item 9, insert the following:
'Push the SMD end of the purple FM INPUT cable through the hole near the top of the power supply interface connector P1.'

Page 6-6, Table 6-2:
Delete MP64, 1400-0937, CLIP-CMPNT.
Delete MP65, 0361-0512, RIVET-SEMITUB.

Page 6-7, Table 6-2:
Delete W12, 11869-20025, AUX OUT CABLE (OPT. 006).
Delete **OPTION 006**
(INCLUDES THE FOLLOWING)
W12, 11869-20025, AUX OUT CABLE, OPT 006
J2, 86290-60005, CONNECTOR ASSY (TYPE N) (AUX OUT).

Page 6-8, Figure 6-1:
Replace Figure 6-1 with **Mechanical Parts (1 of 2) (CHANGE A)** and **Mechanical Parts (2 of 2) (CHANGE A)** in this section.

Page 8-7, Figure 8-3:

Delete W12 AUX OUTPUT (OPT. 006 REAR PANEL).

Page 8-24, Figure 8-11:

Replace Figure 8-11 with **11869A Major Assemblies** from this section.

CHANGE B

Page 6-6, Table 6-2:

Change W2 HP and Mfr. Part Number to 11869-60002, CD6.

CHANGE C

Page 1-4, Table 1-1:

In the paragraph headed **Plug-In Compatibility with the 11869A/8350A**, delete the following:

'The Modulation Select Switch on the 11869A Connector Board selects the correct path for the squarewave modulation signal from the 8350A for use with each Plug-In.'

Page 2-7, Figure 2-5:

Delete Item 3, **Setting the Modulation Select Switch**, and Table 2-1, **Modulation Select Switch Settings**.

Page 3-1, Paragraph 3-2:

Change to read as follows:

'The HP 11869A RF Plug-In Adapter has only one operating control, the Plug-In Identification Switch A1S1 located on the top panel. This switch is set prior to installation. The setting varies according to the individual Plug-In to be installed. (See Section II of this Manual for instructions).'

Page 3-1, Paragraph 3-3.

Delete the first sentence.

Page 6-5, Table 6-2:

Change A1J2 to HP Part Number 1200-0626 CD3 SOCKET-IC 20-CONT DIP-SLDR.

Change A2 HP and Mfr. Part Number to 11869-60016 CD8.

Delete A2CR2.

Delete A2R9.

Delete A2S1.

Page 8-18, Figure 8-8:

Replace Figure 8-8 with the **A2 Connector Board Parts Location Diagram (CHANGE C)** in this section.

Page 8-19

Under **A2 CONNECTOR BOARD THEORY**, change the second sentence of the second paragraph to read:

'Other signals are routed through the Level Shifter circuit.'

Change **INTERFACE AND MODULATION SELECT** to **'INTERFACE'**.

Under **INTERFACE (C)** Delete all except the first paragraph.

Page 8-21, Figure 8-9:

Change A2 to HP Part Number 11869-60016.

Change the A2 Connector Board Schematic according to the partial schematic **P/O A2 Connector Board Schematic (CHANGE C)** in this section.

Page 8-23, Figure 8-10:

Replace Figure 8-10 with the **Cable Interconnect Schematic (CHANGE C)** in this section.

CHANGE D

Page 6-5, Table 6-2:

Change A2 HP and Mfr. Part Number to 11869-60011 CD7.

Change A2J1 to HP Part Number 1200-0626 CD3 SOCKET-IC 20-CONT
DIP-SLDR.

Delete A2J4.

Page 6-6, Table 6-2:

Delete W4P1 and its component parts as follows:

Delete HP Part Number 1251-4050.

Delete HP Part Number 1251-3967.

Delete HP Part Number 1251-3963.

Page 8-18, Figure 8-8:

Replace Figure 8-8 with the **A2 Connector Board Parts Location Diagram (CHANGE D)** in this section.

Page 8-21, Figure 8-9:

Change A2 to HP Part Number 11869-60011.

Change the A2 Connector Board Schematic according to the partial schematic **P/O A2 Connector Board Schematic (CHANGE D)** in this section.

Page 8-23, Figure 8-10:

Replace Figure 8-10 with the **Cable Interconnect Schematic (CHANGE D)** in this section.

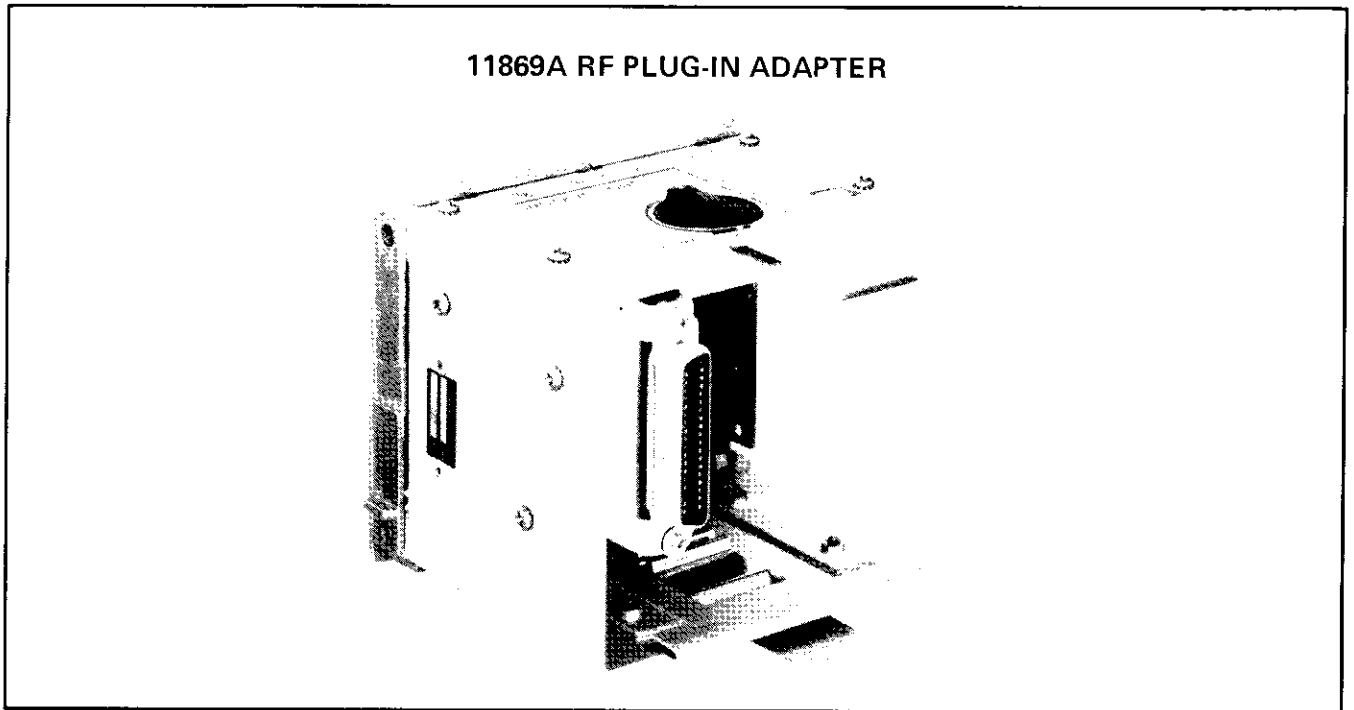

Figure 7-1. 11869A RF Plug-In Adapter (CHANGE A)

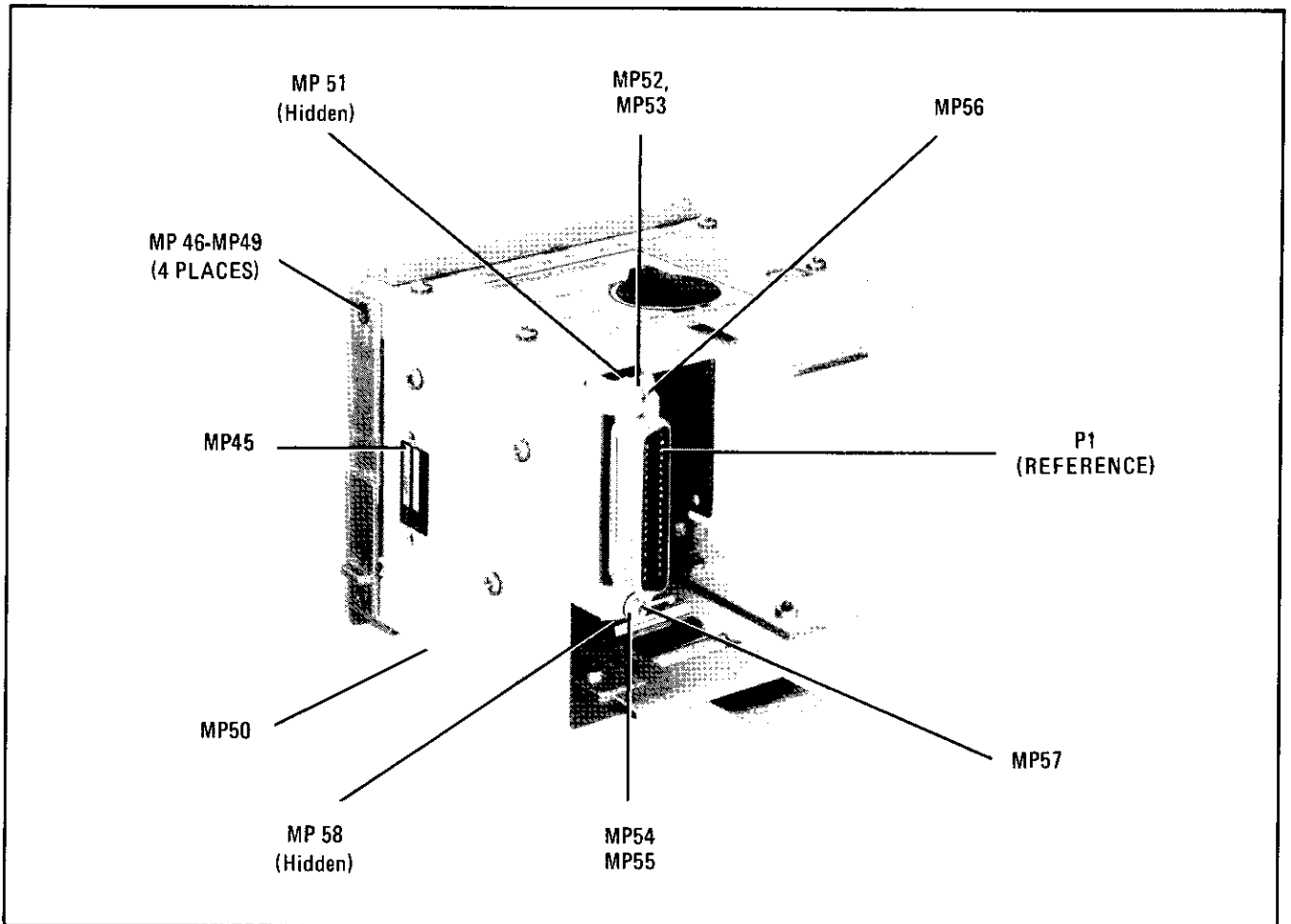

Figure 7-2. Mechanical Parts (1 of 2) (CHANGE A)

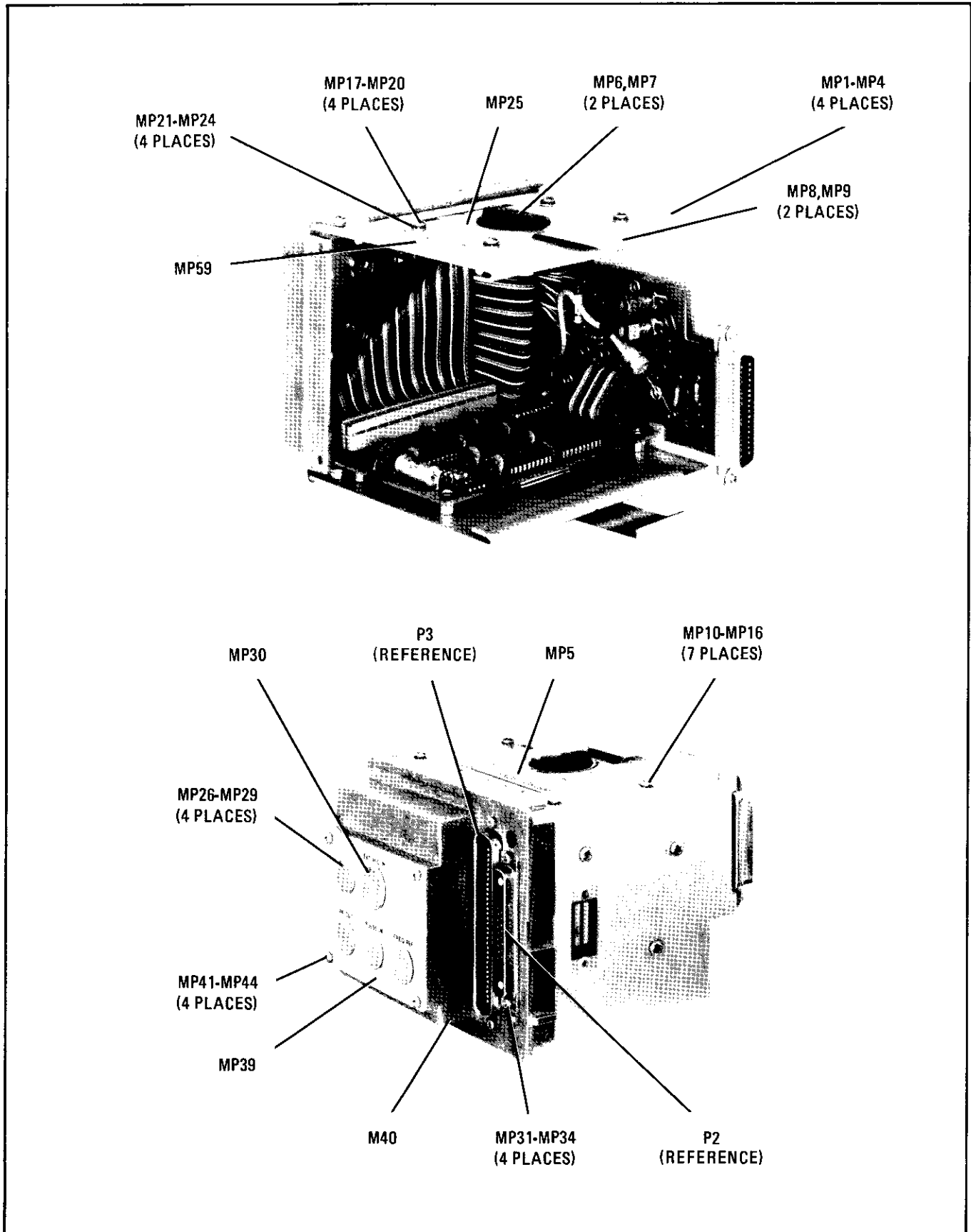

Figure 7-2. Mechanical Parts (2 of 2) (CHANGE A)

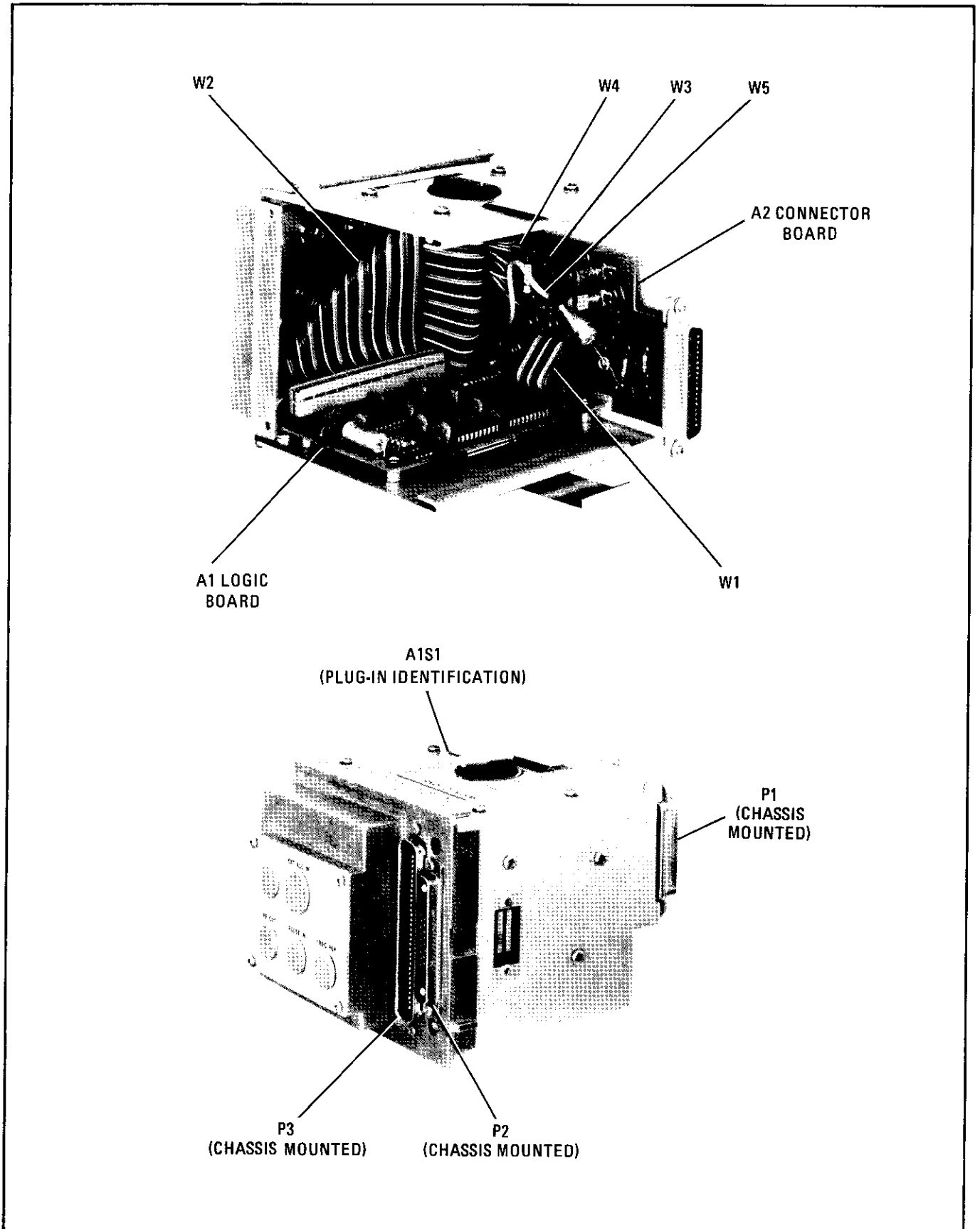

Figure 7-3. 11869A Major Assemblies

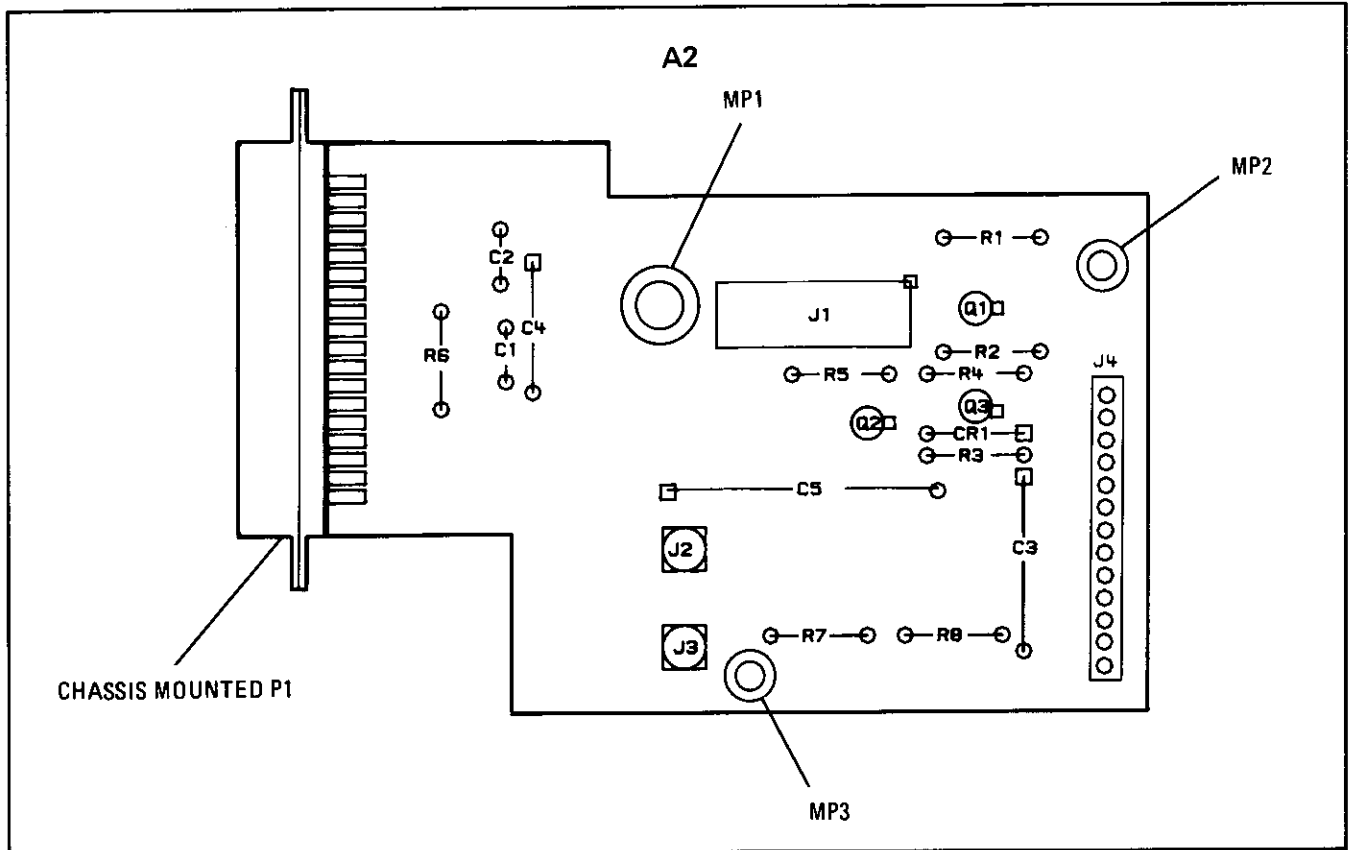

Figure 7-4. A2 Connector Board Parts Location Diagram (CHANGE C)

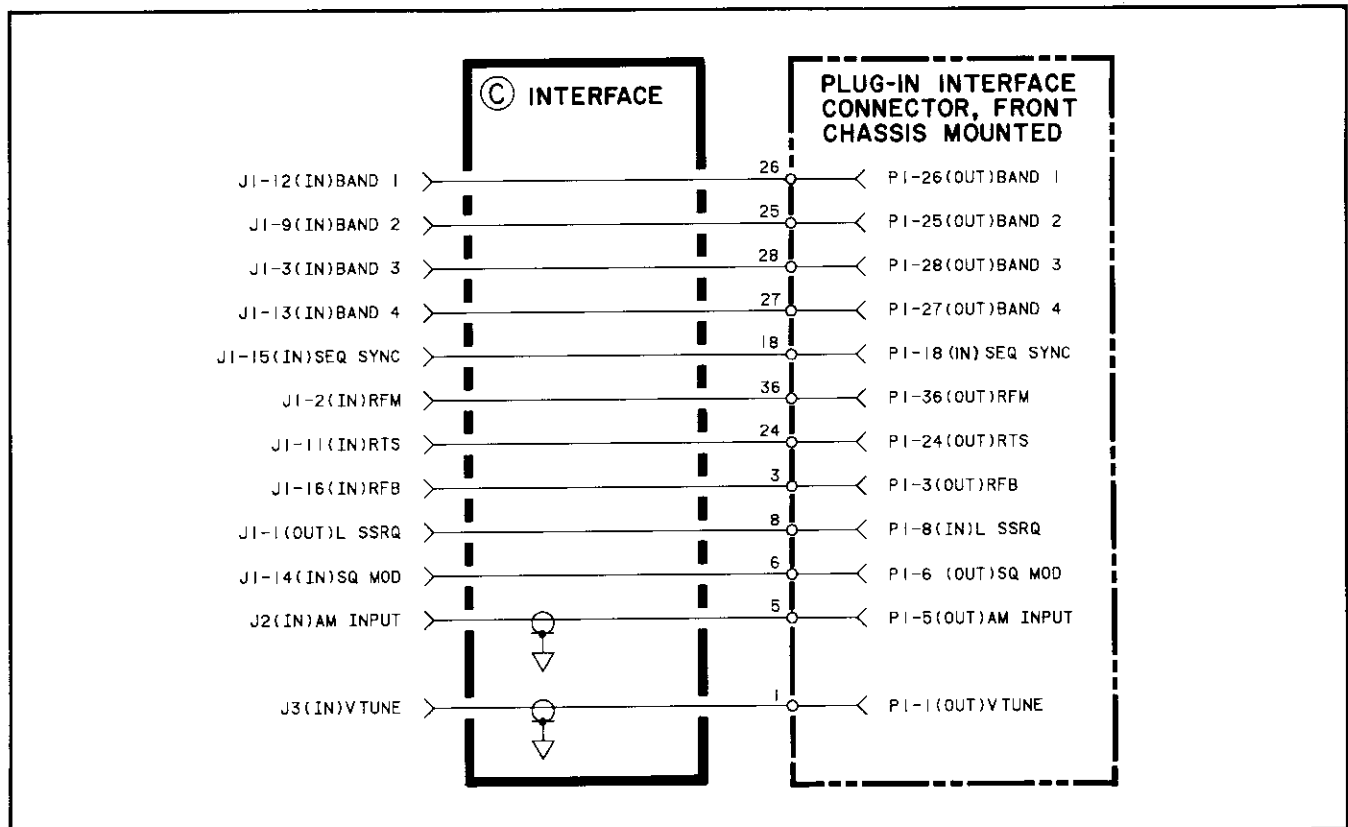

Figure 7-5. P/O A2 Connector Board Schematic (CHANGE C)

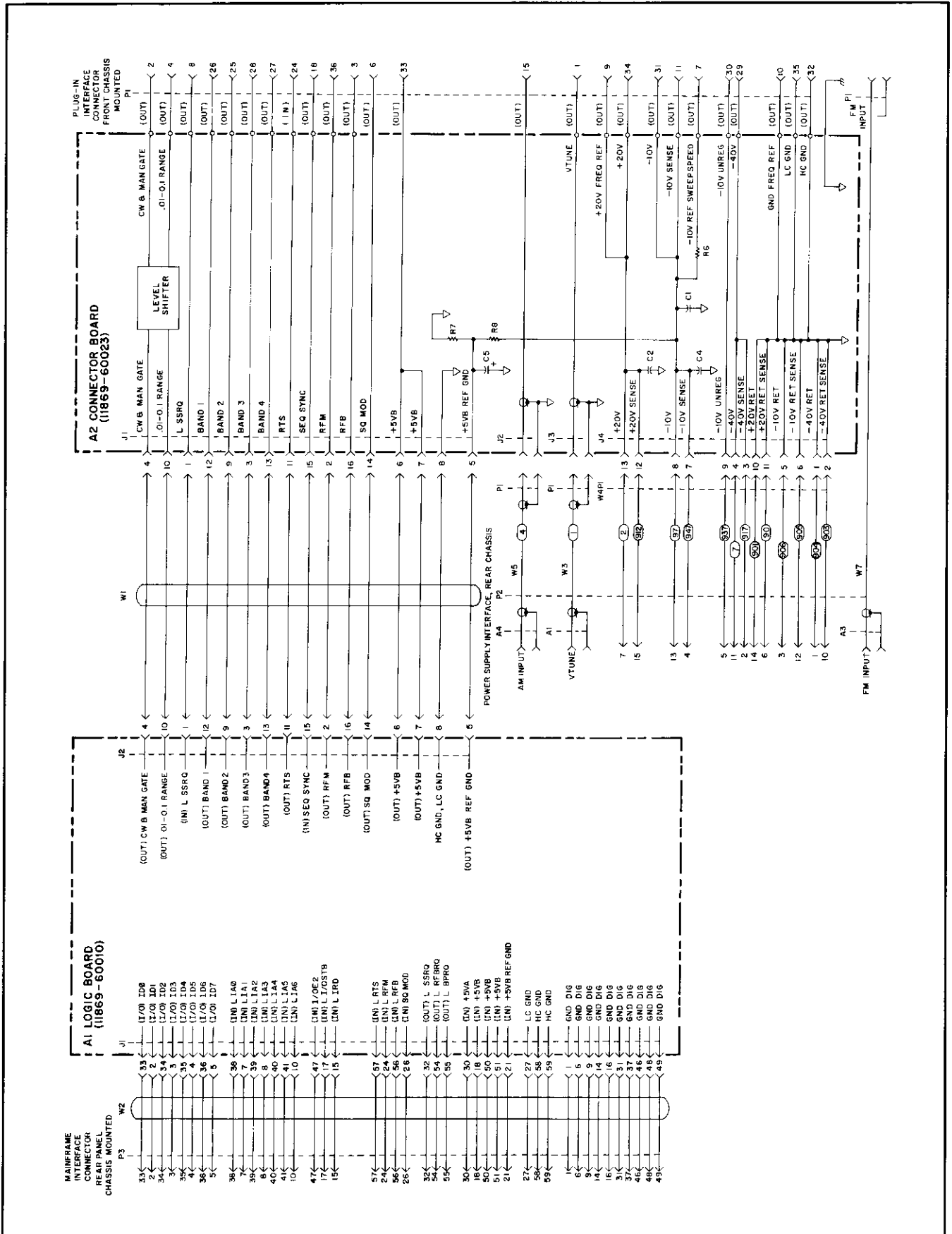

Figure 7-6. Cable Interconnect Schematic (CHANGE C)

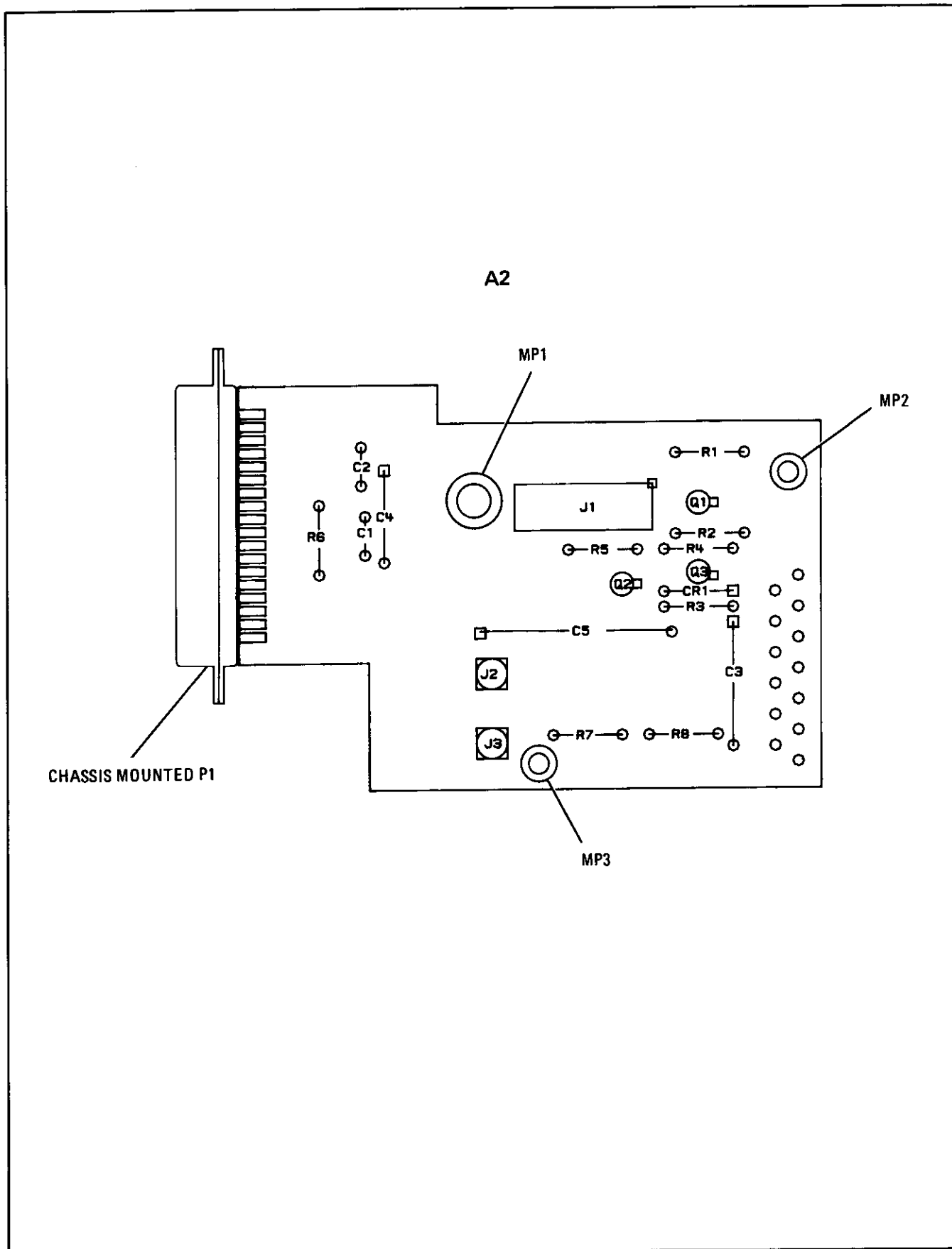

Figure 7-7. A2 Connector Board Parts Location Diagram (CHANGE D)

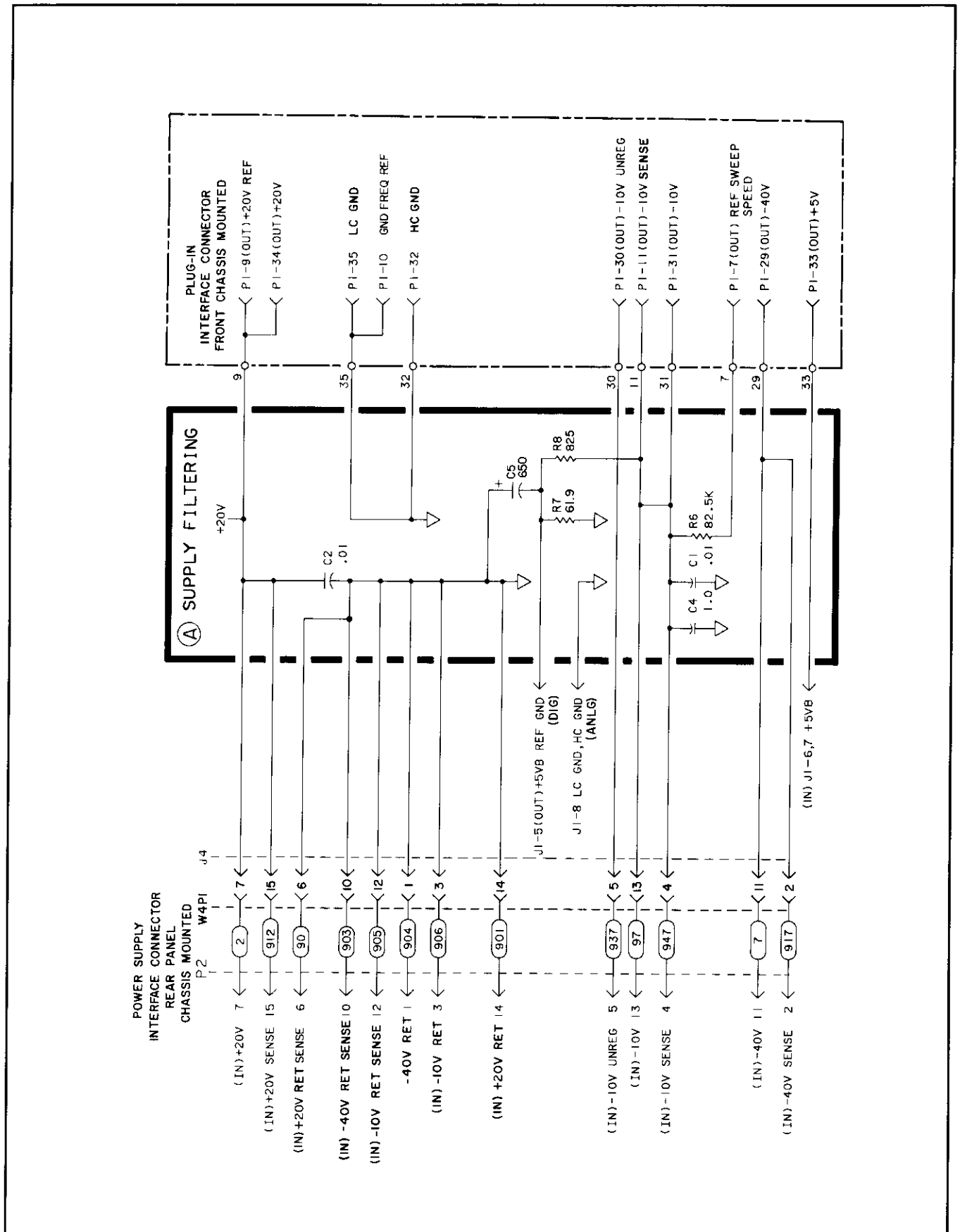

Figure 7-8. P/O A2 Connector Board Schematic (CHANGE D)

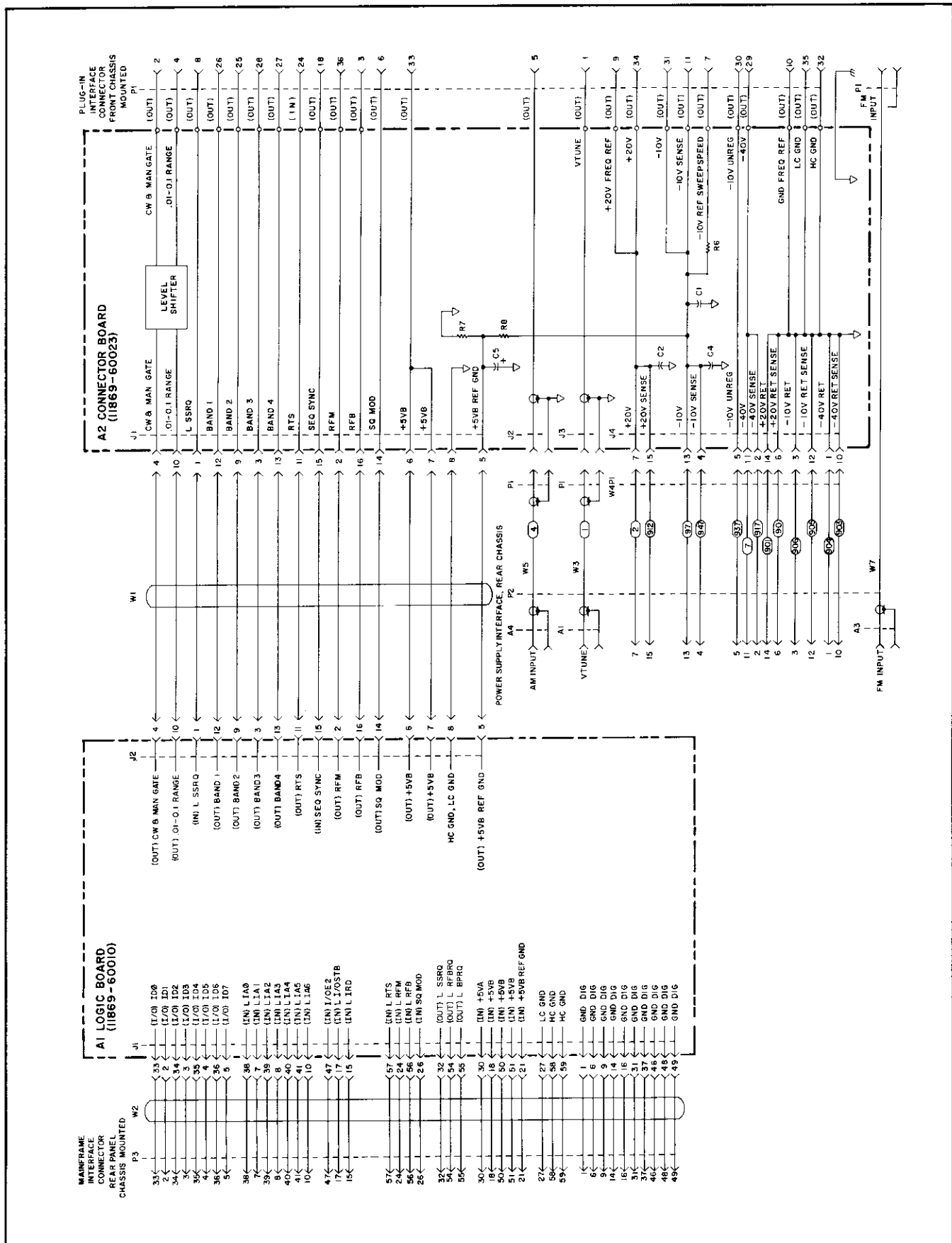

Figure 7-9. Cable Interconnect Schematic (CHANGE D)